



Installation, Operation, and Maintenance

Series E™ CVHH Water-Cooled CenTraVac™ Chillers With Tracer AdaptiView™ Control



Model: CVHH

X39641257003

⚠ SAFETY WARNING

Only qualified personnel should install and service the equipment. The installation, starting up, and servicing of heating, ventilating, and air-conditioning equipment can be hazardous and requires specific knowledge and training. Improperly installed, adjusted or altered equipment by an unqualified person could result in death or serious injury. When working on the equipment, observe all precautions in the literature and on the tags, stickers, and labels that are attached to the equipment.

March 2015

CVHH-SVX001C-EN





Introduction

Read this manual thoroughly before operating or servicing this unit.

Warnings, Cautions, and Notices

Safety advisories appear throughout this manual as required. Your personal safety and the proper operation of this machine depend upon the strict observance of these precautions.

The three types of advisories are defined as follows:

⚠ WARNING Indicates a potentially hazardous situation which, if not avoided, could result in death or serious injury.

⚠ CAUTION Indicates a potentially hazardous situation which, if not avoided, could result in minor or moderate injury. It could also be used to alert against unsafe practices.

NOTICE: Indicates a situation that could result in equipment or property-damage only accidents.

Important Environmental Concerns

Scientific research has shown that certain man-made chemicals can affect the earth's naturally occurring stratospheric ozone layer when released to the atmosphere. In particular, several of the identified chemicals that may affect the ozone layer are refrigerants that contain Chlorine, Fluorine and Carbon (CFCs) and those containing Hydrogen, Chlorine, Fluorine and Carbon (HCFCs). Not all refrigerants containing these compounds have the same potential impact to the environment. Trane advocates the responsible handling of all refrigerants-including industry replacements for CFCs and HCFCs.

Important Responsible Refrigerant Practices

Trane believes that responsible refrigerant practices are important to the environment, our customers, and the air conditioning industry. All technicians who handle refrigerants must be certified according to local rules. For the USA, the Federal Clean Air Act (Section 608) sets forth the requirements for handling, reclaiming, recovering and recycling of certain refrigerants and the equipment that is used in these service procedures. In addition, some states or municipalities may have additional requirements that must also be adhered to for responsible management of refrigerants. Know the applicable laws and follow them.

⚠ WARNING

Proper Field Wiring and Grounding Required!

Failure to follow code could result in death or serious injury. All field wiring **MUST** be performed by qualified personnel. Improperly installed and grounded field wiring poses **FIRE** and **ELECTROCUTION** hazards. To avoid these hazards, you **MUST** follow requirements for field wiring installation and grounding as described in NEC and your local/state/national electrical codes.



Note: Graphic labels (shown above) are used for CE application only.

Important:

- Before servicing, disconnect all power sources and allow at least 30 minutes for capacitors to discharge.
- All electrical enclosures—unit or remote—are IP2X.

⚠ WARNING

Personal Protective Equipment (PPE) Required!

Installing/servicing this unit could result in exposure to electrical, mechanical and chemical hazards.

- Before installing/servicing this unit, technicians **MUST** put on all PPE required for the work being undertaken (Examples; cut resistant gloves/sleeves, butyl gloves, safety glasses, hard hat/bump cap, fall protection, electrical PPE and arc flash clothing). **ALWAYS** refer to appropriate Material Safety Data Sheets (MSDS)/Safety Data Sheets (SDS) and OSHA guidelines for proper PPE.
- When working with or around hazardous chemicals, **ALWAYS** refer to the appropriate MSDS/SDS and OSHA/GHS (Global Harmonized System of Classification and Labelling of Chemicals) guidelines for information on allowable personal exposure levels, proper respiratory protection and handling instructions.
- If there is a risk of energized electrical contact, arc, or flash, technicians **MUST** put on all PPE in accordance with OSHA, NFPA 70E, or other country-specific requirements for arc flash protection, **PRIOR** to servicing the unit. **NEVER PERFORM ANY SWITCHING, DISCONNECTING, OR VOLTAGE TESTING WITHOUT PROPER ELECTRICAL PPE AND ARC FLASH CLOTHING. ENSURE ELECTRICAL METERS AND EQUIPMENT ARE PROPERLY RATED FOR INTENDED VOLTAGE.**

Failure to follow instructions could result in death or serious injury.

⚠ WARNING

Refrigerant May Be Under Positive Pressure!

Failure to recover refrigerant to relieve pressure or the use of non-approved refrigerants, refrigerant substitutes, or refrigerant additives could result in an explosion which could result in death or serious injury or equipment damage. System contains oil and refrigerant and may be under positive pressure. Recover refrigerant to relieve pressure before opening the system. See unit nameplate for refrigerant type. Do not use non-approved refrigerants, refrigerant substitutes, or refrigerant additives.

⚠ WARNING

Replace Manual in Cabinet After Use!

Failure to replace this Installation, Operation, and Maintenance manual in cabinet after use could prevent personnel from accessing necessary safety information and could result in death or serious injury or equipment damage.

NOTICE:

Do Not Use Non-Compatible Parts or Materials!

Use of non-compatible parts or materials could result in equipment damage. Only genuine Trane® replacement components with identical Trane part numbers should be used in Trane CenTraVac chillers. Trane assumes no responsibility for damages resulting from the use of non-compatible parts or materials.



Note: Graphic labels (shown above) are used for CE application only.

Copyright

This document and the information in it are the property of Trane, and may not be used or reproduced in whole or in part without written permission. Trane reserves the right to revise this publication at any time, and to make changes to its content without obligation to notify any person of such revision or change.

Trademarks

All trademarks referenced in this document are the trademarks of their respective owners.

Revision History

CVHH-SVX001C-EN (31 Mar 2015)

- Labels added for clarification:
 - kPaA = kPa Absolute
 - kPaD = kPa Differential
 - kPaG = kPa Gauge
- Clarification of refrigerant container return ([“Installation Requirements and Contractor Responsibilities,”](#) p. 11)
- Revised instruction for placement and tightening of flow probe ([“Water Flow Detection Controller and Sensor—ifm efector,”](#) p. 23)
- “Equipment Damage” notice added to [p. 39](#) and [p. 94](#)
- Revised specifications for conduit used with 110/120 V customer wiring in [“Power Supply Wiring,”](#) p. 51
- Added [“CE for Medium Voltage Starter,”](#) p. 64
- Added recommended material for cleaning material ifm efector[®] flow detection sensors ([Table 20, p. 94](#))

Factory Warranty Information

Compliance with the following is required to preserve the factory warranty:

All Unit Installations

Startup **MUST** be performed by Trane, or an authorized agent of Trane, to **VALIDATE** this WARRANTY. Contractor must provide a two-week startup notification to Trane (or an agent of Trane specifically authorized to perform startup).

Additional Requirements for Units Requiring Disassembly

When a new fully assembled chiller is shipped and received from our Trane manufacturing location and, for any reason, it requires disassembly or partial disassembly—which could include but is not limited to the evaporator, condenser, control panel, compressor/motor, purge, factory-mounted starter or any other components originally attached to the fully assembled unit—compliance with the following is required to preserve the factory warranty:

- Trane, or an agent of Trane specifically authorized to perform start-up and warranty of Trane[®] products, will perform or have direct on-site technical supervision of the disassembly and reassembly work.
- The installing contractor must notify Trane—or an agent of Trane specifically authorized to perform startup and warranty of Trane[®] products—two weeks in advance of the scheduled disassembly work to coordinate the disassembly and reassembly work.
- Start-up must be performed by Trane or an agent of Trane specifically authorized to perform startup and warranty of Trane[®] products.

Trane, or an agent of Trane specifically authorized to perform start-up and warranty of Trane[®] products, will provide qualified personnel and standard hand tools to perform the disassembly work at a location specified by the contractor. Trane, or an agent of Trane specifically authorized to perform start-up and warranty of Trane products, will perform or have direct on-site supervision of the disassembly and reassembly work. The contractor shall provide the rigging equipment such as chain falls, gantries, cranes, forklifts, etc. necessary for the disassembly and reassembly work and the required qualified personnel to operate the necessary rigging equipment.

Important: Any deviation from these requirements must be agreed upon prior to startup in a written agreement from Trane.



Table of Contents

Introduction	2	Strainers	22
Warnings, Cautions, and Notices	2	Required Flow-Sensing Devices	22
Important Environmental Concerns	2	Evaporator and Condenser Water Piping	25
Important Responsible Refrigerant Practices	2	Water Piping Connections	26
Table of Contents	5	Waterbox Locations	26
Unit and Compressor Nameplates	8	Grooved Pipe Coupling	27
Unit Nameplate	8	Flange-Connection Adapters	27
Compressor Nameplate	9	Victaulic Gasket Installation	28
Model Number Descriptions	10	Bolt-Tightening Sequence for Water Piping Connections	29
CVHH CenTraVac Chiller Description	10	Flanges with 8 or 12 Bolts	29
CCHH Centrifugal Compressor Description	10	Flanges with 16 or 20 Bolts	29
Pre-Installation	11	Pressure Testing Waterside Piping	29
ASHRAE Standard 15 Compliance	11	Vent Piping	30
Unit Shipment	11	Refrigerant Vent Line	30
General Information	11	General Requirements	30
Installation Requirements and Contractor Responsibilities	11	Purge Discharge	30
Storage Requirements	13	Vent Line Materials	30
Unit Components	14	Vent Line Sizing	30
Unit Clearances and Weights	15	Vent Line Installation	31
Recommended Unit Clearances	15	Trane RuptureGuard	34
General Weights	16	General Information	34
Installation: Mechanical	17	Connection to External Vent Line and Drip Leg	34
Operating Environment	17	Insulation	39
Foundation Requirements	17	Unit Insulation Requirements	39
Rigging	17	Insulation Thickness Requirements	39
Standard Chiller Lift	17	Installation: Controls	41
Special Lift Requirements	19	UC800 Specifications	41
Unit Isolation	19	Wiring and Port Descriptions	41
Isolation Pads	19	Communication Interfaces	42
Spring Isolators	19	Rotary Switches	42
Leveling the Unit	21	LED Description and Operation	42
Installation: Water Piping	22	Installing the Tracer AdaptiView Display	44
Overview	22	Adjusting the Tracer AdaptiView Display Arm	45
Water Treatment	22	Electrical Requirements	46
Pressure Gauges	22	Installation Requirements	46
Valves—Drains and Vents	22	Electrical Requirements	46



Table of Contents

Trane-Supplied Remote Starter Wiring . . .	48	Tracer AdaptiView Display	72
Customer-Supplied Remote Starter Wiring	49	RuptureGuard	73
Current Transformer and Potential Transform- er Wire Sizing	50	EarthWise Purge	73
Power Supply Wiring	51	How a Purge System Works	73
Three-Phase Power	51	Start-up and Shut-down	77
Circuit Breakers and Fused Disconnects .	52	Chiller Sequence of Operation	77
CE for Control Power Transformer (CPTR) Op- tion	52	Software Operation Overview Diagram . .	77
CE for Starter or Drive	52	Start-up Sequence of Operation—Wye-Delta	78
Control Power Transformer (CPTR) Option	54	Power Up Diagram	80
Power Factor Correction Capacitors (Optional)	54	Ice Machine Control	80
Interconnecting Wiring	56	Free Cooling Cycle	82
Starter to Motor Wiring (Remote-Mounted Starters Only)	57	Hot Water Control	82
Ground Wire Terminal Lugs	57	Control Panel Devices and Unit-Mounted De- vices	83
Terminal Clamps	58	Unit Control Panel	83
Wire Terminal Lugs	58	User-Defined Language Support	83
Bus Bars	58	Unit Start-up and Shut-down Procedures .	83
Starter to Control Panel Wiring	59	Daily Unit Start-up	84
Medium Voltage Installation	61	Seasonal Unit Start-up	84
Medium Voltage Motor	61	Daily Unit Shut-down	84
Motor Terminal Box	61	EarthWise Purge Sequence of Operations	85
Motor Supply Wiring	62	Purge Operating Modes	85
CE for Medium Voltage Starter	64	Air Removal	89
System Control Circuit Wiring (Field Wiring)	65	Pump-out Operating Sequence	89
Water Pump Interlock Circuits and Flow Switch Input	66	Carbon Tank and Regeneration Subsystem	90
Temperature Sensor Circuits	67	Recommended Maintenance	93
Optional Control and Output Circuits . . .	68	Record Keeping Forms	93
Optional Tracer Communication Interface	68	Normal Operation	94
Unit Start-up/Commissioning	68	Compressor Oil Change	95
Starter Module Configuration	68	Leak Checking Based on Purge Pump Out Time	95
Schematic Wiring Drawings	68	RuptureGuard Maintenance	96
Operating Principles	69	EarthWise Purge Maintenance	96
General Requirements	69	Weekly Maintenance	96
Cooling Cycle	69	Semi-Annual Maintenance	97
Oil and Refrigerant Pump	70	Annual Maintenance	97
Motor Cooling System	72	Inspecting the Moisture Indicator	97
		Maintaining the Moisture-Indicating Sight Glass	97

Removing Air After Servicing the Chiller	97
Recommended System Maintenance . . .	98
Waterbox Removal and Installation	100
Discussion	100
Procedure	100
Reassembly	101
Torque Requirements	101
Bolt-Tightening Sequence for Waterboxes	102
Evaporator Waterbox Covers	102
Condenser Waterbox Covers	102
Heat Recovery Condenser Waterbox Covers	103
Forms and Check Sheets	104



Unit and Compressor Nameplates

Unit Nameplate

The unit nameplate is located on the left side of the control panel. A typical unit nameplate is illustrated in [Figure 1](#) and contains the following information:

- Unit model and size descriptor
- Unit electrical requirements
- Correct operating charge and refrigerant type
- Unit test pressures and maximum operating pressures
- Unit literature

Serial Number. The unit serial number provides the specific chiller identity. Always provide this serial number when calling for service or during parts identification.

Service Model Number. The service model represents the unit as built for service purposes. It identifies the selections of variable unit features required when ordering replacements parts or requesting service.

Note: Unit-mounted starters are identified by a separate number found on the starter.

Product Description Block. The CenTraVac™ models are defined and built using the Product Definition and Selection (PDS) system. This system describes the product offerings using a product coding block which is made up of feature categories and codes that identifies all characteristics of a unit.

Figure 1. Typical unit nameplate

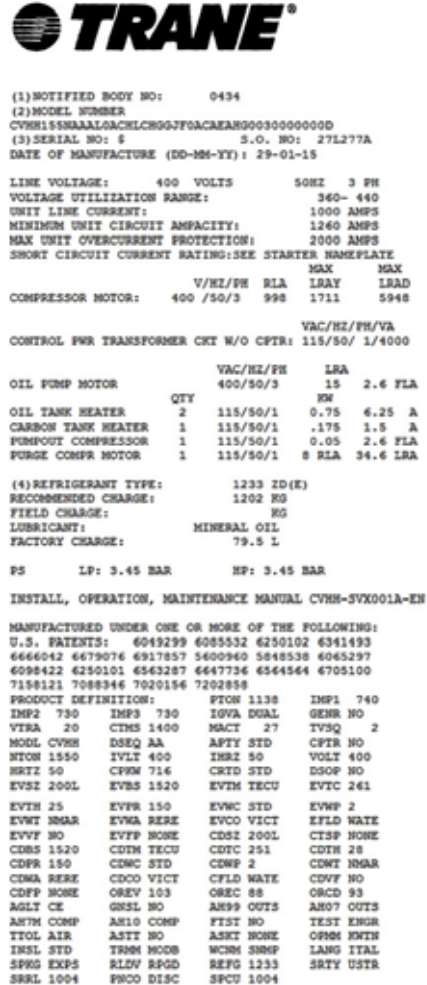

Compressor Nameplate

The compressor assembly has a separate model number which is required to identify internal and external compressor parts. The model number begins with "CCHH" and the nameplate is located on the foot of the volute.

Figure 2. Compressor nameplate

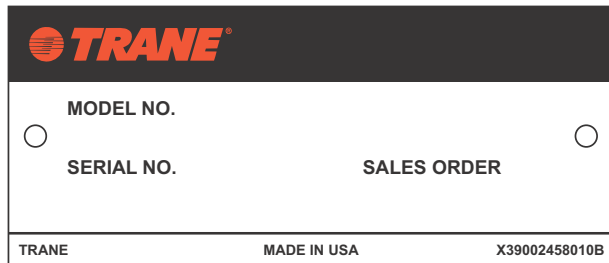

Note: The serial number space on the compressor nameplate will be intentionally left blank.



Model Number Descriptions

CVHH CenTraVac Chiller Description

- Digit 1, 2 — Simplex CenTraVac™ Chiller
- Digit 3 — Direct Drive
- Digit 4 — Development Sequence
- Digit 5, 6, 7 — Nominal Total Compressor Tonnage
- Digit 8 — Unit Motor Voltage
- Digit 9 — Unit Type
- Digit 10, 11 — Design Sequence
- Digit 12 — Manufacturing Location
- Digit 13 — Hot Gas Bypass (HGB)
- Digit 14 — Starter Type
- Digit 15 — Control Enclosure
- Digit 16 — Evaporator Shell Size
- Digit 17 — Evaporator Tube Bundle
- Digit 18 — Evaporator Tubes
- Digit 19 — Evaporator Waterbox
- Digit 20 — Condenser Shell Size
- Digit 21 — Condenser Tube Bundle
- Digit 22 — Condenser Tubes
- Digit 23 — Condenser Waterboxes
- Digit 24 — Auxiliary Condenser Size and Waterboxes
- Digit 25, 26 — Evaporator Orifice Size
- Digit 27, 28 — Economizer Orifice Size
- Digit 29, 30 — Condenser Orifice Size
- Digit 31 — Unit Option
- Digit 32 — Control: Enhanced Protection
- Digit 33 — Control: Extended Operation
- Digit 34 — Tracer™ Communication Interface
- Digit 35 — Special Options

- Digit 36 — Control: Water Flow Control
- Digit 37 — Control: Chilled Water Reset
- Digit 38 — Control: Heat Recovery/Auxiliary Temperature Sensors
- Digit 39 — Industrial Chiller Package (INDP)
- Digit 40 — Control Power Transformer (CPTR)
- Digit 41 — Thermal Dispersion Water Flow Proving
- Digit 42 — Compressor Motor Frame Size

CCHH Centrifugal Compressor Description

The compressor assembly has a separate model number which is required to identify internal and external compressor parts. The model number begins with "CCHH" and the nameplate is located on the foot of the volute.

- Digit 1, 2 — Unit Function
- Digit 3 — Drive
- Digit 4 — Development Sequence
- Digit 5, 6, 7 — Nominal Total Compressor Tonnage
- Digit 8 — Compressor Motor Voltage
- Digit 9 — Compressor Motor Frame Size
- Digit 10, 11 — Design Sequence
- Digit 12 — Manufacturing Location
- Digit 13, 14, 15, 16 — Compressor Motor Power (kW)
- Digit 17, 18, 19, 20 — First Stage Compressor Impeller (IMPI)
- Digit 21, 22, 23, 24 — Second Stage Compressor Impeller (IMP2)
- Digit 25, 26, 27, 28 — Third Stage Compressor Impeller (IMP3)
- Digit 29 — Motor and Terminal Board Configuration
- Digit 30 — Resistent Temperature Detector



Pre-Installation

ASHRAE Standard 15 Compliance

Trane recommends that indoor CenTraVac unit installations fully meet or exceed the guidelines of the current version of ASHRAE Standard 15, in addition to any applicable national, state, or local requirements. This typically includes:

- A refrigerant monitor or detector that is capable of monitoring and alarming within the acceptable exposure level of the refrigerant, and that can actuate mechanical ventilation.
- Audible and visual alarms, activated by the refrigerant monitor, inside the equipment room and outside of every entrance.
- The equipment room should be properly vented to the outdoors, using mechanical ventilation that can be activated by the refrigerant monitor.
- The purge discharge and the rupture disk must be properly piped to the outdoors.
- If required by local or other codes, a self-contained breathing apparatus should be available in close proximity to the equipment room.

For the USA, refer to the latest copy of ASHRAE Standard 15 for specific guidelines. Trane assumes no responsibility for any economic, health, or environmental issues that may result from an equipment room's design or function.

Unit Shipment

Inspect unit while it is still on the truck for any shipping damage. The chiller ships shrink-wrapped in a 0.254 mm (0.010-in.) recyclable film protective covering. Do not remove shrink-wrap for inspection! Inspect for damage to the shrink-wrap and determine if physical damage has occurred.

Each chiller ships from the factory as a hermetically assembled package; it is factory-assembled, -wired, and -tested. All openings except for the waterbox vent and drain holes are covered or plugged to prevent contamination during shipment and handling. [Figure 3, p. 14](#) shows an illustration of a typical unit and its components. As soon as the unit arrives at the job site, inspect it thoroughly for damage and material shortages. In addition:

1. Verify the hermetic integrity of the unit by checking the chiller pressure for an indication of holding charge pressure.
2. To prevent damaging moisture from entering the unit and causing corrosion, each chiller is pressurized with 20.7 to 34.5 kPaG (3 to 5 psig) of dry nitrogen before shipment.

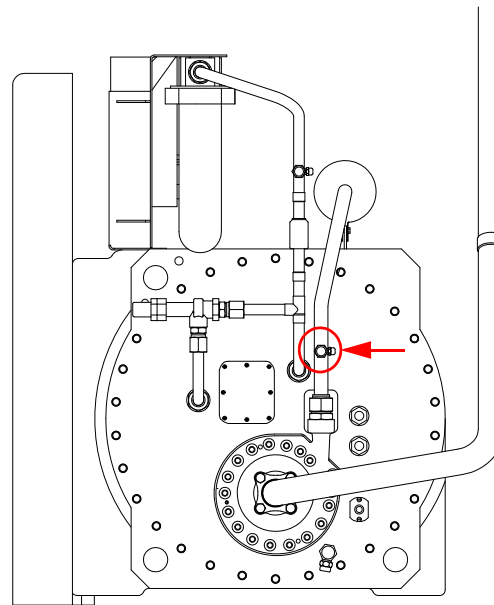

Note: The holding charge should register approximately 34.5 kPaG (5 psig) at 22.2°C (72°F). Place a gauge on the access valve provided (indicated by arrow and circle in the preceding figure) on the refrigerant pump discharge line to verify the holding charge. This access valve is located on the front of the oil tank, which is at the right rear corner of the chiller. If the charge has escaped, contact your local Trane sales office for instructions.

3. The loose parts box and isolator pads ship on top of the control panel box.
4. Check the oil sump sight glasses to verify that the sump was factory-charged with 79.5 L (21 gallons) of oil. The oil level should be visible to about halfway in the top sight glass. If no oil level is visible, contact your local Trane sales office.

General Information

Regulations regarding waste handling are constantly changing. To ensure that personnel are in compliance with the latest federal, state and local regulations, contact your local waste management office for the proper procedures on handling, disposal, transporting and storage of oil, oil filters, refrigerant filters, and filter dryer cores.

Installation Requirements and Contractor Responsibilities

A list of the contractor responsibilities typically associated with the unit installation process is provided.



Pre-Installation

Note: The chiller should remain within its protective shrink-wrap covering during storage.

⚠ WARNING

Combustible Material!

Failure to follow this instruction could result in death or serious injury or equipment damage. Shrink-wrap is a combustible material. Avoid open flames and hot sparks.

Type of Requirement	Trane Supplied Trane Installed	Trane Supplied Field Installed	Field Supplied Field Installed
Foundation			<ul style="list-style-type: none"> Meet foundation requirements
Rigging			<ul style="list-style-type: none"> Safety chains Clevis connectors Lifting beam
Disassembly/Reassembly (as required)	<ul style="list-style-type: none"> Trane will perform or have direct on-site supervision of the disassembly and reassembly work (contact your local Trane office for pricing) 		
Isolation		<ul style="list-style-type: none"> Isolation pads or spring isolators 	<ul style="list-style-type: none"> Isolation pads or spring isolators
Electrical	<ul style="list-style-type: none"> Circuit breakers or fusible disconnects (optional) Unit mounted starter (optional) PFCCs (optional) 	<ul style="list-style-type: none"> Jumper bars Temperature sensor (optional outdoor air) Flow switches (may be field supplied) Remote-mounted starter (optional) 	<ul style="list-style-type: none"> Circuit breakers or fusible disconnects (optional) Electrical connections to unit mounted starter (optional) Electrical connections to remote mounted starter (optional) Wiring sizes per submittal and NEC or local codes PFCCs (remote mounted starter optional only) Terminal lugs Ground connection(s) Jumper bars BAS wiring (optional) IPC wiring (AFD and remote-mounted starters only) Control voltage wiring (AFD and remote-mounted starters only) Oil pump interlock wiring (AFD and remote mounted starters only) High condenser pressure interlock wiring (AFD and remote mounted starters only) Chilled water pump contactor and wiring including interlock Condenser water pump contactor and wiring including interlock Option relays and wiring
Water piping		<ul style="list-style-type: none"> Flow sensing devices (may be field supplied) 	<ul style="list-style-type: none"> Taps for flow sensing devices Taps for thermometers and gauges Thermometers Strainers (as required) Water flow pressure gauges Isolation and balancing valves in water piping Vents and drain on waterbox valves (one each per pass) Pressure relief valves (for waterboxes as required)
Relief	<ul style="list-style-type: none"> Rupture disk assembly RuptureGuard™ (optional) 		<ul style="list-style-type: none"> Vent line and flexible connector and vent line from rupture disk to atmosphere
Insulation	<ul style="list-style-type: none"> Insulation (optional) 		<ul style="list-style-type: none"> Insulation Chiller feet insulation
Water Piping Connection Components	Flanged (optional)	Flanged (optional) <ul style="list-style-type: none"> Victaulic® to flange adapter for 1034.2 kPaG (150 psig) waterboxes 	Victaulic <ul style="list-style-type: none"> Victaulic coupling for 1034.2 kPaG (150 psig) and 2068.4 kPaG (300 psig) waterboxes Fasteners for flanged-type connections (optional)
Other Materials			<ul style="list-style-type: none"> Material and equipment to perform leak testing Dry nitrogen (55.2 kPaG [8 psig] maximum per machine as needed)

Type of Requirement	Trane Supplied Trane Installed	Trane Supplied Field Installed	Field Supplied Field Installed
"CenTraVac™ Installation Completion Check Sheet and Request for Trane Service" (CTV-ADF001*-EN; refer to "Forms and Check Sheets," p. 104)			<ul style="list-style-type: none"> To be completed by installing contractor prior to contacting Trane for start-up
Chiller start-up commissioning ^(a)	<ul style="list-style-type: none"> Trane, or an agent of Trane specifically authorized to perform start-up of Trane® products 		
Post-commissioning transport of empty refrigerant containers for return or recycling			<ul style="list-style-type: none"> Move empty refrigerant containers to an easily accessible point of loading

(a) Start-up must be performed by Trane or an agent of Trane specifically authorized to perform start-up and warranty of Trane® products. Contractor shall provide Trane (or an agent of Trane specifically authorized to perform start-up) with notice of the scheduled start-up at least two weeks prior to the scheduled start-up.

Storage Requirements

NOTICE:

Insulation Damage!

Do not expose unit to direct sunlight as it could result in damage to factory-installed insulation.

Less than 1 month	1–6 months	Greater than 6 months
Location requirements: <ul style="list-style-type: none"> solid foundation vibration free dry temperature range -40°C to 70°C (-40°F to 158°F) 	Location requirements: <ul style="list-style-type: none"> solid foundation vibration free dry temperature range -40°C to 70°C (-40°F to 158°F) 	Location requirements: <ul style="list-style-type: none"> solid foundation vibration free dry temperature range -40°C to 70°C (-40°F to 158°F)
<ul style="list-style-type: none"> Do not remove any plastic coverings Do not charge the chiller with refrigerant If additional refrigerant is on site, follow manufactures storage requirements 	<ul style="list-style-type: none"> Do not remove any plastic coverings Do not charge the chiller with refrigerant If additional refrigerant is on site, follow manufactures storage requirements 	<ul style="list-style-type: none"> Do not remove any plastic coverings Do not charge the chiller with refrigerant If additional refrigerant is on site, follow manufactures storage requirements
<ul style="list-style-type: none"> Verify dry nitrogen pressure using gauge located on the evaporator shell reads 20.7 to 34.5 kPaG (3 to 5 psig) Notify the local Trane office if charge has escaped 	<ul style="list-style-type: none"> Verify dry nitrogen pressure using gauge located on the evaporator shell reads 20.7 to 34.5 kPaG (3 to 5 psig) Notify the local Trane office if charge has escaped 	<ul style="list-style-type: none"> Verify dry nitrogen pressure using gauge located on the evaporator shell reads 20.7 to 34.5 kPaG (3 to 5 psig) Notify the local Trane office if charge has escaped
<ul style="list-style-type: none"> Do not operate purge unit 	<ul style="list-style-type: none"> Do not operate purge unit Verify waterbox and tube bundles are clean and dry 	<ul style="list-style-type: none"> Do not operate purge unit Verify waterbox and tube bundles are clean and dry Conduct an oil analysis and verify no oil breakdown^(a) Repeat yearly Replace oil if breakdown has occurred If no oil analysis program has been followed, replace oil prior to start up

Note: Chillers stored 5 years or longer should be inspected every 5 years by a qualified service organization for leaks.

(a) If protective plastic coverings need to be removed for access and/or service, contact your local Trane office.

Unit Components

Note: The control panel side of the unit is always designated as the front side of the unit.

Figure 3. Typical Simplex CVHH CenTraVac chiller

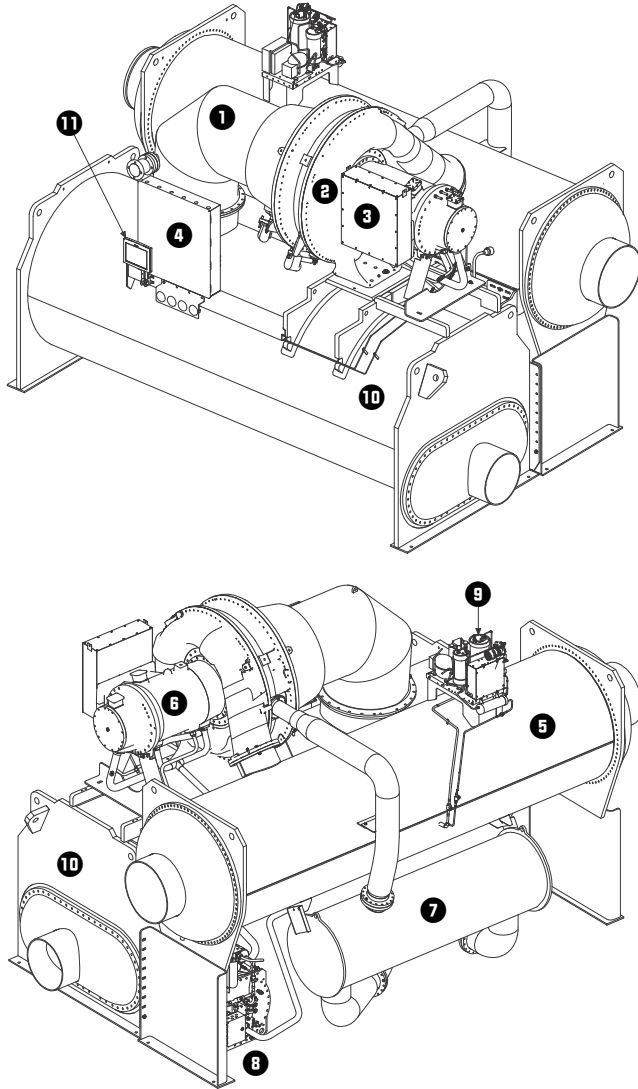

- | | |
|------------------|----------------------|
| 1. Suction Elbow | 7. Economizer |
| 2. Compressor | 8. Oil Tank Assembly |
| 3. Terminal Box | 9. Purge |
| 4. Control Panel | 10. Evaporator |
| 5. Condenser | 11. Display Panel |
| 6. Motor Housing | |



Unit Clearances and Weights

Recommended Unit Clearances

Adequate clearances around and above the chiller are required to allow sufficient access for service and maintenance operations. Specific unit clearance requirements are indicated in the submittal package provided for your unit.

- Do NOT install piping or conduit above the compressor motor assembly or behind the suction elbow of the unit.

- Minimum vertical clearance above the unit is 92 cm (3 feet).
- Use a housekeeping pad to provide better service clearances; refer to submittal for more information.

Per NEC Article 110: Unit mounted starters from 0–600V require a 107 cm (42 inch) clearance, 601–2500V require a 122 cm (48 inch) clearance, and 2501–9000V require a 152 cm (60 inch) clearance. Refer to NEC and local electrical codes for starter and control panel clearance requirements.

Figure 4. Clearance requirements

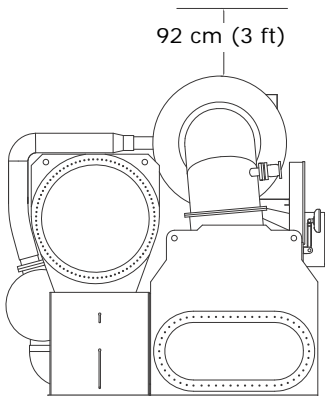
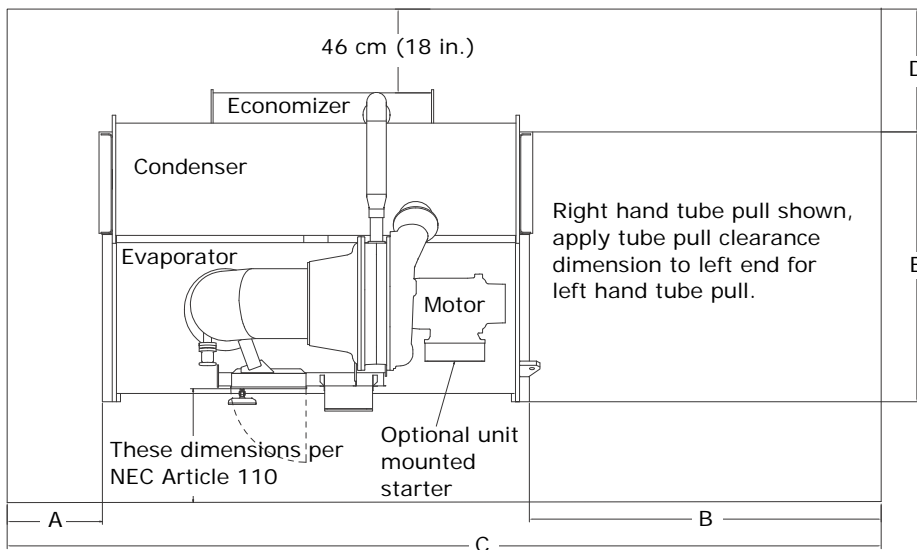



Unit Clearances and Weights

Table 1. Clearance requirements^(a)

Shell Combo	A		B		C		D		E	
	cm	in.	cm	in.	cm	in.	cm	in.	cm	in.
100M/100M	213	84	422	166	1057	416	30	12	310	122
100M/10HM	213	84	422	166	1057	416	79	31	300	118
100L/100L	213	84	422	186	1161	457	30	12	310	122
130M/130M	224	88	422	166	1067	420	74	29	277	109
130M/13HM	224	88	422	166	1067	420	79	31	312	123
160M/200M	244	96	422	166	1087	428	94	37	285	112
160M/20HM	244	96	422	166	1087	428	91	36	325	128
200L/200L	272	107	472	186	1217	479	86	34	282	111
200L/20HL	272	107	472	186	1217	479	94	37	333	131
200L/220L	272	107	472	186	1219	480	94	37	305	120
220L/220L	305	120	472	186	1252	493	97	38	300	118
220L/22HL	305	120	472	186	1250	492	107	42	363	143

(a) All dimensions are approximate; refer to the unit submittal package for exact dimensions for your unit.

General Weights

The unit weight information provided in Table 2 should be used for general information purposes only. Trane does not recommend using this weight information for considerations relative to chiller handling. The large number of variances between chiller selections drives variances in chiller weights that are not recognized in this table. For specific weights for your chiller, refer to your submittal package.

The values in Table 2 representing chiller weights include the following:

- TECU 0.028-in. (0.71 mm) tube wall.
- 1034.2 kPaG (150 psig) non-marine waterboxes.
- Operating weights include the largest possible refrigerant charge.

- Chillers with starter weights include the weight of the heaviest possible starter.
- Heaviest possible bundle and heaviest possible motor combination for the application family chiller.

The values in Table 2 representing chiller weights do NOT include the following options:

- INDP (Industrial Control Panel) option—add 23 kg (50 lb)
- CPTR (Control Panel Transformer) option—add 127 kg (280 lb)
- SMP (Supplemental Motor Protection) option—add 230 kg (500 lb)

Table 2. Unit weights

MODEL	NTON	Hz	EVSZ	CDSZ	Weight without Starters				Weight with Starters			
					Operating		Shipping		Operating		Shipping	
					kg	lb	kg	lb	kg	lb	kg	lb
CVHH	900–1200	60	100M	100M	19748	43538	17218	37959	20044	44190	17514	38611
	900–1200	60	100L	100L	20562	45331	17802	39246	20858	45983	18097	39898
	900–1200	60	100M	10HM	21946	48382	19226	42386	22241	49034	19522	43038
	900–1200	60	130M	130M	22193	48927	19019	41929	22489	49579	19314	42581
	900–1200	60	130M	13HM	24873	54836	21522	47447	25169	55488	21817	48099
	900–1200	60	160M	200M	25523	56269	21503	47405	25819	56921	21798	48057
	900–1200	60	160M	20HM	28516	62868	24353	53690	28812	63520	24649	54342
	900–1200	60	200L	220L	28443	62707	23780	52425	28739	63359	24075	53077
	900–1200	60	220L	220L	30193	66564	25080	55291	30489	67216	25375	55943
	1700–1500	60	200L	200L	27480	60583	23188	51120	27776	61235	23483	51772
	1700–1500	60	200L	20HL	30683	67644	26248	57867	30979	68296	26544	58519
	1700–1500	60	220L	220L	30588	67434	25474	56161	30883	68086	25770	56813
	1700–1500	60	220L	22HL	34497	76053	29234	64451	34793	76705	29530	65103
	1550	50	200L	200L	28456	62735	24164	53272	28752	63387	24459	53924
	1550	50	200L	20HL	31659	69796	27224	60019	31955	70448	27520	60671
	1550	50	220L	220L	31564	69586	26450	58313	31859	70238	26746	58965
	1550	50	220L	22HL	35473	78205	30211	66603	35769	78857	30506	67255



Installation: Mechanical

Operating Environment

Important:

- The standard chiller is designed for indoor use only and as such has NEMA Type 1 or IP 20 enclosures.
- For chillers in unheated equipment rooms, contact your local Trane service agency for methods to ensure that the oil temperature is maintained suitable for proper operation of the chiller.

To ensure that electrical components operate properly, do not locate the chiller in an area exposed to dust, dirt, corrosive fumes, or excessive heat and humidity. The ambient temperature range for chiller operation is 1.1°C to 40°C (34°F to 104°F).

NOTICE:

Equipment Failure!

Unit operating at ambient temperatures exceeding 40°C (104°F) could result in starter component damage due to the panel's inability to dissipate heat adequately. If any of these adverse operating conditions are present, take necessary action to improve the equipment room environment.

Foundation Requirements

Chiller mounting surface must be:

- rigid non-warping mounting pads or a concrete foundation.
- able to support the chiller at its full operating weight (including completed piping, and full operating charges of refrigerant, oil and water.)

For proper unit operation, the chiller must be level within 1.6 mm (1/16 in.) over its length and width when set into place on the mounting surface. [Table 2, p. 16](#) shows approximate weights for various chiller sizes and options.

Note: For specific weight information, refer to the unit submittal package.

Important: Trane will not assume responsibility for equipment problems resulting from an improperly designed or constructed foundation.

Rigging

Lifting is the recommended method for moving chillers. Suggested lifting arrangements for standard units are described in "[Standard Chiller Lift](#)," p. 17.

Note: The lifting beam used for Simplex units must be at least 4.572 meters (15 feet) long.

⚠ WARNING

Heavy Objects!

Failure to properly lift unit could result in death or serious injury, or equipment or property-only damage. Do not use cables (chains or slings) except as shown in [Figure 5, p. 18](#). Each of the cables (chains or slings) used to lift the unit must be capable of supporting the entire weight of the unit. Lifting cables (chains or slings) may not be of the same length. Adjust as necessary for even unit lift.

⚠ WARNING

Improper Unit Lift!

Failure to properly lift unit could result in death or serious injury, or equipment or property-only damage.

- Test lift unit approximately 61 cm (24 inches) to verify proper center of gravity lift point. To avoid dropping of unit, reposition lifting point if unit is not level.
- Do not lift chiller utilizing waterbox lifting lug. Waterbox lifting lug is to be used only for removing waterbox from chiller.
- Do not lift chiller utilizing elbow lifting tab. Elbow lifting tab and approved clevis are used when removing elbow from chiller.

NOTICE:

Wiring Damage!

Damage to unit wiring could result in equipment failure. Care must be taken during rigging, assembly and disassembly to avoid damaging unit wiring.

Standard Chiller Lift

⚠ WARNING

5.72-cm (2.25-in.) Diameter Clevis Required to Lift Units!

Failure to follow instructions below could result in death or serious injury. A clevis with a 5.72-cm (2.25-in.) diameter pin MUST be used to lift these units. Using a smaller clevis would cause too much stress to the 5.72-cm (2.25-in.) lifting holes which could result in pull-out of the lifting holes causing the unit to drop from the rigging.

1. Insert clevis connections at the points indicated in [Figure 5, p. 18](#). A 63.5 mm (2.5 in.) diameter lifting hole is provided at each of these points.
2. Attach the lifting chains or cables.

Installation: Mechanical

- Once the lifting cables are in place, attach a safety chain or cable between the first-stage casing of the compressor and the lifting beam.

Important: There should not be tension on this safety cable; the cable is used only to prevent the unit from rolling during the lift.

- Position isolator pads or spring isolators beneath the chiller feet (refer to “Unit Isolation,” p. 19 for instructions).

Note: Follow instructions provided by the spring isolator manufacturer, being careful to not damage isolator adjustment bolt.

- Once the isolators are in place, lower the chiller—working from end to end—in small increments to maintain stability.
- When lift is complete, detach the clevis connections and safety chain.

Figure 5. Typical rigging arrangements for Simplex units

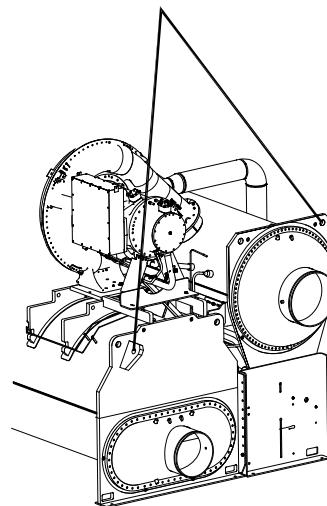
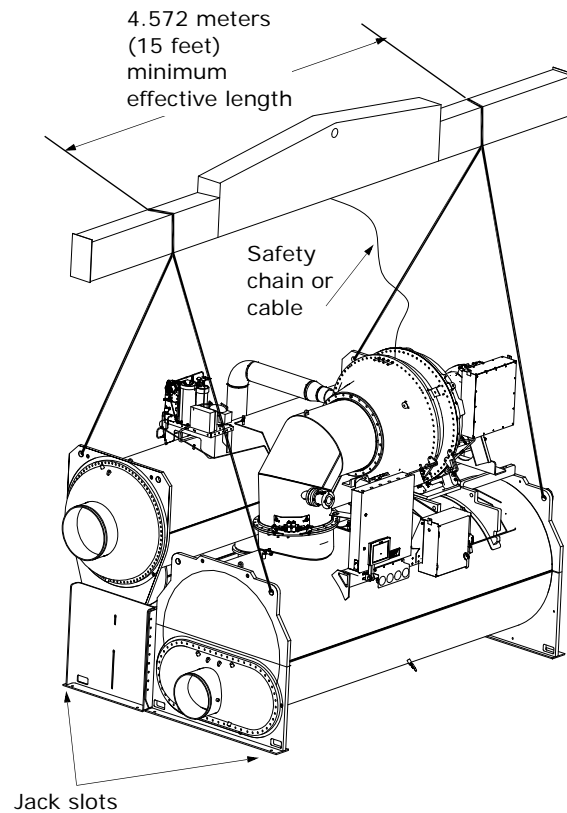

Special Lift Requirements

NOTICE:

Oil Loss!

Failure to prevent oil migration out of the oil tank could result in equipment failure or property-only damage. To prevent oil migration out of the oil tank during lifting procedures, remove the oil from the oil tank if the unit will be lifted at any angle greater than 15° from horizontal end-to-end. If oil is allowed to run out of the oil tank into other areas of the chiller, it will be extremely difficult to return the oil to the oil tank even during operation.

NOTICE:

Equipment Damage!

Moving the chiller using a fork lift could result in equipment or property-only damage. Do not use a fork lift to move the chiller!

NOTICE:

Compressor Alignment!

Failure to preserve compressor alignment could result in equipment or property-only damage. Lifting the compressor/motor assembly from the shells without factory-installed doweling in the compressor casting flanges could result in misalignment of the compressor castings.

If the chiller cannot be moved using a standard chiller lift, consider the following:

- When job site conditions require rigging of the chiller at an angle greater than 45° from horizontal (end-to-end), the unit may require removal of the compressor. Contact Trane or an agent of Trane specifically authorized to perform start-up and warranty of Trane® products regarding the disassembly and reassembly work. For more information, refer to [“Factory Warranty Information,” p. 4.](#)

Note: Disassembly and reassembly work includes dowel-pinning the compressor and removing it from the unit. Contact Trane or an agent of Trane specifically authorized to perform start-up and warranty of Trane® products for specific rigging instructions. Do NOT attempt to rotate the chiller onto its side.

- When lifting the chiller is either impractical or undesirable, attach cables or chains to the jacking slots shown in [Figure 5, p. 18](#); then push or pull the unit across a smooth surface. Should the chiller be on a shipping skid, it is not necessary to remove the skid from the chiller before moving it into place.
- If removal of the compressor or economizer assembly is necessary to move the chiller to the operating

location, contact Trane. For more information, refer to [“Factory Warranty Information,” p. 4.](#)

Unit Isolation

To minimize sound and vibration transmission through the building structure, and to ensure proper weight distribution over the mounting surface, always install isolation pads or spring isolators under the chiller feet.

Note: Isolation pads (see [Figure 6](#)) are provided with each chiller unless spring isolators are specified on the sales order.

Specific isolator loading data is provided in the unit submittal package. If necessary, contact your local Trane sales office for further information.

Important: When determining placement of isolation pads or spring isolators, remember that the control panel side of the unit is always designated as the unit front.

Isolation Pads

When the unit is ready for final placement, position isolation pads (457.2-mm sides) end for end under the full length of the chiller leg. The pads measure 228.6 mm x 457.2 mm (9 in. x 18 in.) and on some units there may be small gaps between pads. Pads are provided to cover entire foot.

Figure 6. Isolation pad and dimensions

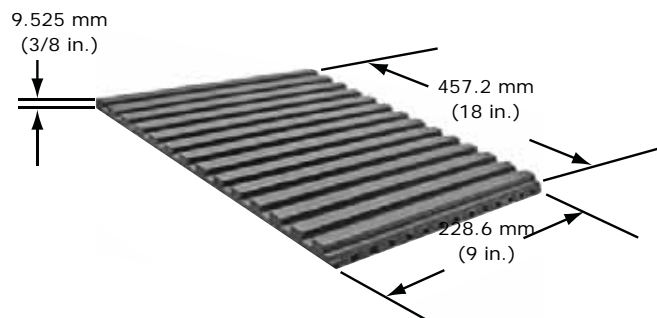

Remember that the chiller must be level within 1.6 mm (1/16 in.) over its length and width after it is lowered onto the isolation pads. In addition, all piping connected to the chiller must be properly isolated and supported so that it does not place any stress on the unit.

Spring Isolators

Spring isolators should be considered whenever chiller installation is planned for an upper story location. Base isolator placement is shown in [Figure 7](#); also refer to [Table 3.](#)

Figure 7. Isolation spring placement by shell size, evaporator and condenser length

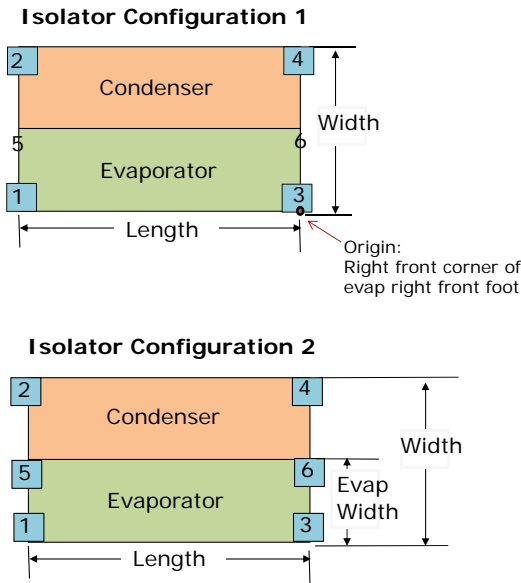

Table 3. Isolation spring placement, cm (in.)

EVSZ	CDSZ	Width	Evap Width	Length	Isolator Config	Origin to Center of Rear Pad	Origin to Center of Middle Pad
200L	200L	285.0 (112.2)	170.2 (67)	457.2 (180)	2	268.5 (105.7)	153.7 (60.5)
220L	220L	303.3 (119.4)	188.0 (74)	457.2 (180)	2	286.8 (112.9)	171.5 (67.5)
200L	20HL	336.0 (132.3)	170.2 (67)	457.2 (180)	2	319.5 (125.8)	153.7 (60.5)
220L	22HL	361.0 (142.5)	188.0 (74)	457.2 (180)	2	345.4 (136)	171.5 (67.5)
160M	20HM	323.3 (127.3)	154.9 (61)	406.4 (160)	2	306.8 (120.8)	138.4 (54.5)
200L	220L	285.2 (112.3)	170.2 (67)	457.2 (180)	2	268.7 (105.8)	153.7 (60.5)
160M	200M	270.3 (106.4)	154.9 (61)	406.4 (160)	2	253.7 (99.9)	138.4 (54.5)
100M	100M	264.4 (104.1)	N/A	406.4 (160)	1	247.9 (97.6)	N/A
100L	100L	264.4 (104.1)	N/A	457.2 (180)	1	247.9 (97.6)	N/A
130M	130M	277.6 (109.3)	N/A	406.4 (160)	1	261.1 (102.8)	N/A
100M	10HM	300.2 (118.2)	N/A	406.4 (160)	1	283.7 (111.7)	N/A
130M	13HM	313.4 (123.4)	N/A	406.4 (160)	1	296.9 (116.9)	N/A

Spring isolators typically ship assembled and ready for installation. To install and adjust the isolators properly, follow the instructions given.

Note: Do not adjust the isolators until the chiller is piped and charged with refrigerant and water.

1. Position the spring isolators under the chiller as shown in Figure 7. Ensure that each isolator is centered in relation to the tube sheet.

Note: Spring isolators shipped with the chiller may not be identical. Compare the data provided in the unit submittal package to determine proper isolator placement.

2. Set the isolators on the sub-base; shim as necessary to provide a flat, level surface at the same elevation for the end supports.

Important: Support the full underside of the isolator base plate; do NOT straddle gaps or small shims.

3. If required, bolt the isolators to the floor through the slots provided, or cement the pads.

Note: Fastening the isolators to the floor is not necessary unless specified.

4. If the chiller must be fastened to the isolators, insert capscrews through the chiller base and into holes drilled and tapped in the upper housing of each isolator.

Important: Do NOT allow the screws to protrude below the underside of the isolator upper housing, or interfere with the adjusting bolts. An alternative method of fastening the chiller to the isolators is to cement the neoprene pads.

5. Set the chiller on the isolators; refer to "Standard Chiller Lift," p. 17. The weight of the chiller will force down the upper housing of each isolator, and could cause it to rest on the isolator's lower housing (refer to Figure 8).

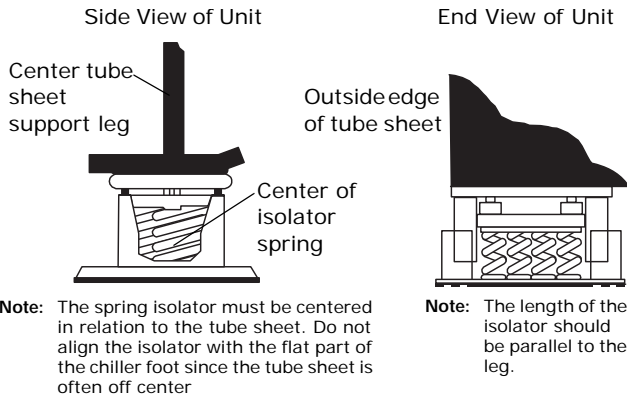
Figure 8. Chiller foot and isolator orientation

compress the springs until either the springs support the load or the top plate rests on the bottom housing of the isolator. If the springs are supporting the load, screwing down on the adjusting bolt (Step 7) will raise the chiller.

7. Turn the adjusting bolt on each of the remaining isolators to obtain the required minimum clearance of 6.35 mm (1/4 in.).
8. Once the minimum required clearance is obtained on each of the isolators, level the chiller by turning the adjusting bolt on each of the isolators on the low side of the unit. Work from one isolator to the next.

Important: The chiller must be level to within 1.6 mm (1/16 in.) over its length and width, and the clearance of each isolator must be at least 6.35 mm (1/4 in.).

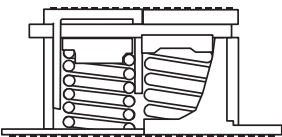
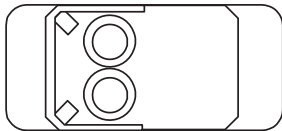

6. Check the clearance on each isolator. If this dimension is less than 6.35 mm (1/4 in.) on any isolator, use a wrench to turn the adjusting bolt one complete revolution upward.

Note: When the load is applied to the isolators (Step 5), the top plate of each isolator moves down to

Leveling the Unit

The chiller must be set level within 1.6 mm (1/16 in.).

1. Measure and make a punch mark an equal distance up from the bottom of each foot of the chiller.
2. Suspend a clear plastic tube along the length of the chiller as shown in the following figure.
3. Fill the tube with water until the level aligns with the punch mark at one end of the chiller.
4. Check the water level at the opposite mark. If the water level does not align with the punch mark, use full length shims to raise one end of the chiller until the water level at each end of the tube aligns with the punch marks at both ends of the chiller.
5. Once the unit is level across its length, repeat Step 1 through Step 3 to level the unit across its width.

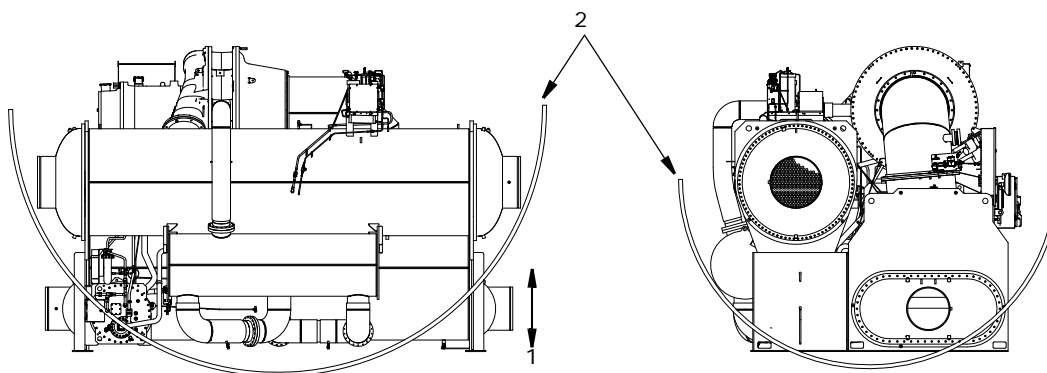
Figure 9.

Note: Use of a laser level is an acceptable alternative method to level the unit.

Important: Immediately report any unit damage incurred during handling or installation at the job site to the Trane sales office.



Installation: Water Piping

Overview

The following water piping circuits must be installed and connected to the chiller:

- Pipe the evaporator into the chilled water circuit.
- Pipe the condenser into the cooling tower water circuit.
- *Optional:* A heat-recovery condenser water circuit.
- *Optional:* An auxiliary condenser water circuit.

Note: Piping must be arranged and supported to avoid stress on the equipment. It is strongly recommended that the piping contractor does not run pipe closer than 0.91 m (3 feet) minimum to the equipment. This will allow for proper fit upon arrival of the unit at the job site. Any adjustment that is necessary can be made to the piping at that time. Expenses that result from a failure to follow this recommendation will not be paid by Trane.

Piping suggestions for each of the water circuits listed above are outlined in “[Evaporator and Condenser Water Piping](#),” p. 25. General recommendations for the installation of field supplied piping components (e.g., valves, flow switches, etc.) common to most chiller water circuits are listed below.

Water Treatment

The use of untreated or improperly treated water in a CenTraVac may result in inefficient operation and possible tube damage.

Important: Trane strongly recommends using the services of a qualified water treatment specialist to determine necessary water treatment. A label with a customer disclaimer note is affixed to each unit.

NOTICE:

Proper Water Treatment!

Trane assumes no responsibility for equipment failures which result from untreated or improperly treated water, or saline or brackish water. The use of untreated or improperly treated water in a CenTraVac could result in scaling, erosion, corrosion, algae or slime. It is recommended that the services of a qualified water treatment specialist be engaged to determine what water treatment, if any, is required.

Pressure Gauges

Locate pressure gauge taps in a straight length of pipe. Place each tap a minimum of one pipe diameter downstream of any elbow, orifice, etc. For example, for a 152.4 mm (6 in.) pipe, the tap would be at least 152.4 mm (6 in.) from any elbow, orifice, etc.

Valves—Drains and Vents

NOTICE:

Waterbox Damage!

Failure to follow instructions could result in damage to the waterbox. Do not over-tighten or use excessive Teflon® pipe tape when installing valves, drains, plugs and vents on waterboxes.

1. Install field-supplied air vents and drain valves on the waterboxes. Each waterbox is provided with a National Pipe Thread Female (NPTF) vent and drain connection; the openings are 19.05 mm (3/4 in.).

NOTICE:

Over-pressurization!

Failure to install pressure-relief valves in the condenser and evaporator water circuits could result in waterbox damage due to hydrostatic expansion.

2. If necessary for the application, install pressure-relief valves at the drain connections on the evaporator and condenser waterboxes. To do so, add a tee with the relief valve attached to the drain valve. Follow local codes for determining if drain connection is large enough for relief devices.

To determine whether or not pressure relief valves are needed for a specific application, keep in mind that:

- a. Vessels with close-coupled shutoff valves may cause high potentially damaging hydrostatic pressures as fluid temperature rises.
- b. Relief valves are required by American Society of Mechanical Engineers (ASME) codes when the waterside is ASME. Follow ASME guidelines or other applicable codes/local regulation to ensure proper relief valve installation.

Strainers

NOTICE:

Tube Damage!

Failure to install strainers in all water piping entering the chiller could result in tube plugging conditions that damage unit components.

Install a strainer in the entering side of each piping circuit to avoid possible tube plugging in the chiller with debris.

Required Flow-Sensing Devices

The ifm efector® flow detection controller and sensor (see “[Water Flow Detection Controller and Sensor—ifm](#)”

efector;" p. 23) are used to verify evaporator and condenser water flows.

If a customer-supplied flow sensing device is used to ensure adequate chiller protection, refer to the wiring diagrams that shipped with the unit for specific electrical connections.

Be sure to follow the manufacturer's recommendations for device selection and installation.

Water Flow Detection Controller and Sensor—*ifm efector*

Figure 10. Installation of ifm efector flow detection controller and sensor

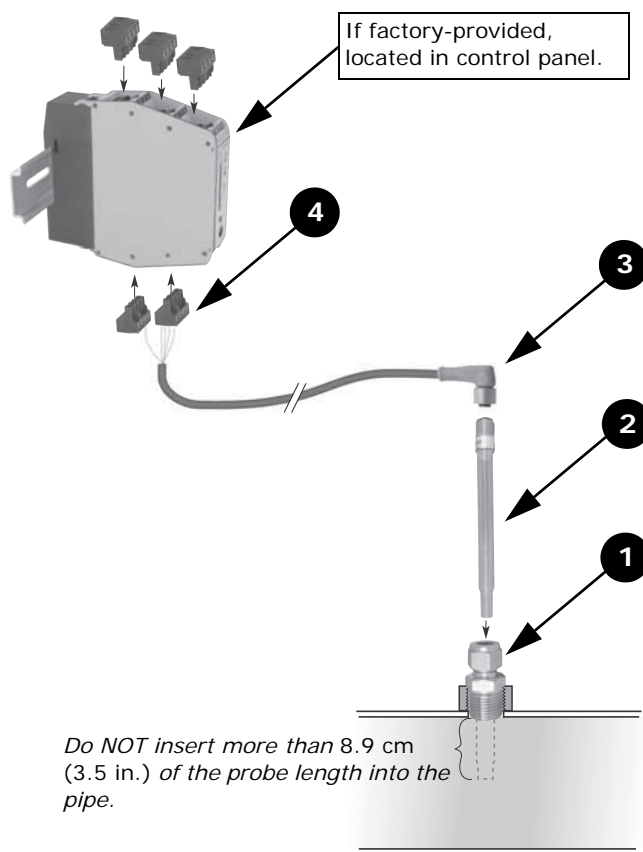

1. Mount the 1/2-in. NPT adapter in a horizontal or vertical section of pipe. The maximum distance from the control panel must not exceed 8.99 meters (29.5 ft) (see item labeled "1" in Figure 10, p. 23). Allow at least five pipe diameters straight run of pipe upstream of the sensor location, and three pipe diameters straight run of pipe downstream of the sensor location.

Note: In the case of a horizontal pipe, mounting the sensor in the side of the pipe is preferred. In the case of a vertical pipe, mounting the sensor in a place where the water flows upwards is preferred.

2. Insert the flow sensor probe (see item labeled "2" in Figure 10, p. 23) through the 1/2-in. NPT adapter so that 7.6–8.9 cm (3–3.5 in.) of the probe's length extends into the pipe. Finger-tighten the 1/2-in. NPT adapter; then, tighten with a wrench an additional 3/4 turns (minimum) to 1 turn (maximum); do NOT overtighten.

Note: When installed, the tip of the ifm efector sensor probe must be at least 2.54 cm (1 in.) away from any pipe wall. Do NOT insert more than 8.9 cm (3.5 in.) of the probe length into the pipe.

3. Install the Micro DC Cable by inserting it through the wire openings on the back side of the control panel (see item labeled "3" in Figure 10, p. 23). Install the supplied Micro DC Cable (9 meters [25 feet] in length) to the Flow Probe and hand-tighten the connector nut.
4. Plug the other end of the Micro DC Cable into the Flow Control Monitor with the Combicon connector (see item labeled "4" in Figure 10, p. 23). Refer to Figure 11 for cable wiring.

NOTICE:
Do Not Apply Electrical Power to a Unit in a Vacuum!
 Failure to disconnect power to units with inside-the-delta solid state starters during evacuation or when the unit is in a deep vacuum could cause compressor motor damage. Applying electrical power to a motor in a vacuum could cause damage to the motor. In addition, on units with inside-the-delta solid state starters, all power to the unit must be disconnected prior to evacuating the unit as line power is directly applied to the motor terminals 4, 5, and 6.



Note: Graphic labels (shown above) are used for CE application only.

Important:

- Before servicing, disconnect all power sources and allow at least 30 minutes for capacitors to discharge.
 - All electrical enclosures—unit or remote—are IP2X.
5. Apply power to the chiller control panel to verify the Flow Control Monitor has power and the Low Volt Broken Wire Relay light is not lit.
 6. Remove all air from the piping circuit prior to adjusting the low water flow setpoint.
 7. Reduce the water flow to the minimum allowable flow and adjust the Flow setting on the Flow Control Monitor (see item labeled "7" in Figure 11). Adjusting the "Flow" potentiometer clockwise (+) reduces the

flow setting cutout and adjusting counterclockwise (-) increases the flow setting cutout.

Note: The "Temp" potentiometer on the ifm effector control module has no effect in Trane application. It is not necessary to make adjustments to the "Temp" potentiometer.

8. Once the cutout setting is adjusted, the cutout setpoint will be indicated with a yellow light on the Flow Control Monitor LED bar graph display. When the water flows are higher than the cutout, a green light will indicate proper flow status. If the flows fall below the cutout setpoint, a red light will indicate low/no flow status.

Figure 11. ifm effector flow sensing device terminal connection

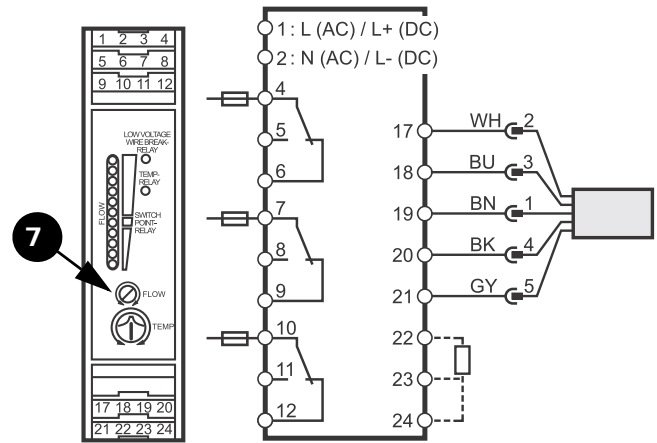

NOTICE:
Proof of Flow Switch!
 Evaporator and condenser water circuits require proof of flow switches.

- Failure to include the proof of flow devices and/or jumping out these devices could cause the unit to stop on a secondary level of protection.
- Frequent cycling on these higher level diagnostic devices could cause excessive thermal and pressure cycling of unit components (O-rings, gaskets, sensors, motors, controls, etc.) and/or freeze damage, resulting in premature failure of the chiller.

Failure to provide flow switches or jumping-out of switches could result in severe equipment damage.

Evaporator and condenser proof of flow switches are required. These switches are used with control logic to confirm flow prior to starting a unit and to stop a running unit if flow is lost. For trouble shooting, a viewable diagnostic is generated if a proof of flow switch does not close when flow is required.

Evaporator and Condenser Water Piping

Figure 12 and Figure 13, p. 25 illustrate the recommended (typical) water piping arrangements for the evaporator and condenser.

Figure 12. Typical evaporator water piping circuit

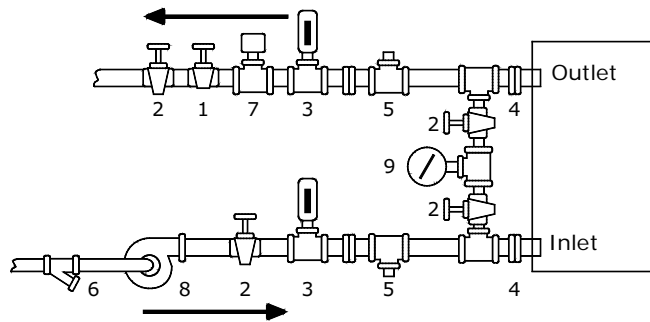

- | | |
|---|---|
| 1. Balancing Valve | 6. Strainer |
| 2. Gate (Isolation) Valve or Ball Valve | 7. Chilled Water Flow Switch (4B4) ^(a) |
| 3. Thermometer (if field supplied) | 8. Pump |
| 4. Waterbox Nozzle Connection | 9. Pressure Gauge ^(b) |
| 5. Drain, Vent, Anode | |

- (a) Flow switch 4B4 may be installed in either the entering or leaving leg of the chilled water circuit.
 (b) It is recommended to pipe the gauge between entering and leaving pipes. A shutoff valve on each side of the gauge allows the operator to read either entering or leaving water pressure.

Figure 13. Typical condenser water piping circuits

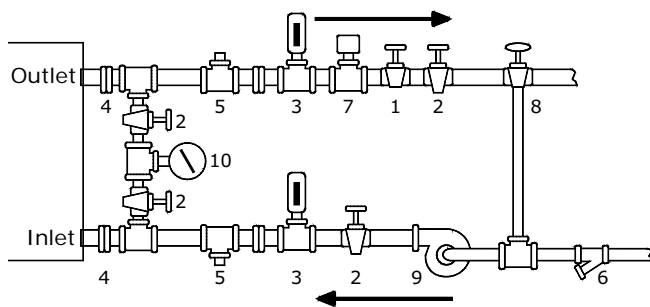

- | | |
|---|---|
| 1. Balancing Valve | 6. Strainer |
| 2. Gate (Isolation) Valve or Ball Valve | 7. Condenser Water Flow Switch (4B5) ^(a) |
| 3. Thermometer (if field supplied) | 8. 3-Way Valve (Optional) |
| 4. Waterbox Nozzle Connection | 9. Condenser Water Pump |
| 5. Drain, Vent, Anode | 10. Pressure Gauge ^(b) |

Notes:

- Some type of field-supplied temperature control device may be required to regulate the temperature of the heat-recovery condenser water circuit. For application recommendations, refer to *Heat Recovery Seminar (Part 2): "Systems/Equipment (AM-FND-8)*.
 - Install a bypass valve system to avoid circulating water through the auxiliary shell when the unit is shut down.
 - On multiple pass condensers, entering condenser water must enter at the lowest nozzle.
- (a) Flow switch 4B5 may be installed in either the entering or leaving leg of the water circuit.
 (b) It is recommended to pipe a single gauge between entering and leaving pipes.

Piping must be arranged and supported to avoid stress on the equipment. It is strongly recommended that the piping contractor does not run pipe closer than 0.91 meters (3 feet) minimum to the equipment. This will allow for proper fit upon arrival of the unit at the job site. Any adjustment that is necessary can be made to the piping at that time. Expenses that result from a failure to follow this recommendation will not be paid by Trane.

Water piping connection sizes and components are identified in Table 4, p. 26 and Table 5, p. 27. Remember that with many waterboxes the entering and leaving evaporator water can be piped to either waterbox connection when the tube bundles are split vertically. However, large evaporator waterboxes, with entering and leaving connections not at the same level, must be connected with the entering water at the bottom and the leaving water at the top.

Waterboxes with multiple pass arrangements utilize a baffle to separate the passes. These baffles are designed for a maximum pressure of 137.9 kPaD (20 psid). If larger pressure drops are expected in the application, contact your local Trane representative to discuss special waterbox options.

Important: Water flows must be piped in accordance with nameplate designation.

Field-provided isolation valves for the evaporator and condenser water lines should be installed upstream and downstream of the heat exchangers, and be installed far enough away from the chiller to also provide practical service isolation for flow sensing devices, field thermometers, flexible connectors, and any removable pipe spools.

Ensure that the evaporator water piping is clear, check it after the chilled water pump is operated but before initial chiller start-up. If any partial blockages exist, they can be detected and removed to prevent possible tube damage resulting from evaporator freeze-up or erosion.

For condenser and large evaporator connections, arrange the water piping so that the water supply enters the shell at the lower connection, and exits from the top connection. Operational problems may result if this piping is not correct. Some shells may be piped as desired since both connections are at the same level.

For applications that include an "infinite source" or "multiple-use" cooling condenser water supply, install a valved bypass "leg" (optional) between the supply and return pipes. This valved bypass allows the operator to short-circuit water flow through the cooling condenser when the supply water temperature is too low.

Note: System refrigerant pressure differential must be maintained above 20.7 kPaD (3 psid) at all times. Failure to do so could result in operating problems.

Water Piping Connections

All standard units use grooved-pipe connections. These are grooved-end NSP (Victaulic style) pipe connections. Flanged connections are optional.

Piping joined using grooved type couplings, like all types of piping systems, requires proper support to carry the weight of pipes and equipment. The support methods used must eliminate undue stresses on joints, piping and other components; allow movement where required, and provide for any other special requirements (i.e., drainage, etc.).

Note: Plug-type sensor extension cables are available for purchase from Trane Parts Service if needed. These sensor extension cables may be necessary if the waterboxes are changed or if the temperature sensors are moved out into the unit piping for better mixed temperature readings.

Table 4. Water connection pipe sizes

Water Passes	Shell Size						
	100	130	160	200	220	400	440
Evaporator							
	Metric Pipe Size (mm)						
1 Pass	DN300	DN300	DN350	DN400	DN500	DN400	DN500
2 Pass	DN250	DN250	DN300	DN350	DN350	—	—
3 Pass	DN200	DN200	DN250	DN300	DN300	—	—
Condenser							
1 Pass	DN300	DN350	—	DN400	DN600	—	DN600
2 Pass	DN250	DN300	—	DN350	DN350	—	—
Evaporator							
	Nominal Pipe Size (in.)						
1 Pass	12	12	14	16	20	16	20
2 Pass	10	10	12	14	14	—	—
3 Pass	8	8	10	12	12	—	—
Condenser							
1 Pass	12	14	—	16	24	—	24
2 Pass	10	12	—	14	14	—	—

Figure 14. Typical grooved pipe connection

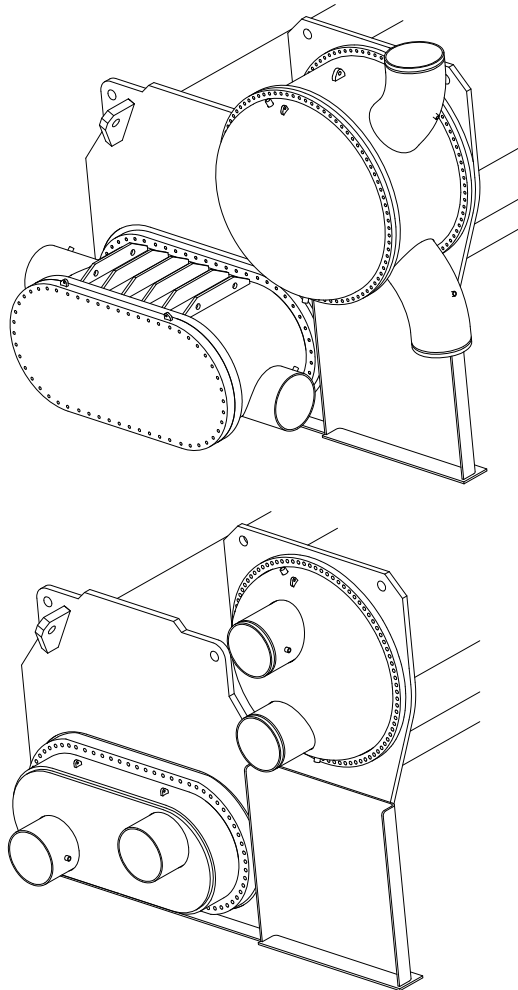

Waterbox Locations

NOTICE:

Do Not Exchange Positions of Heat Recovery Waterboxes!

Failure to follow this instruction could prevent proper unit operation. Contact CenTraVac Technical Service for switching of heat recovery waterboxes.

If necessary, the non-marine-style waterboxes on each shell whether evaporator or condenser can be switched end-for-end to obtain the desired piping arrangement.

If removal of waterboxes is necessary, refer to [“Waterbox Removal and Installation,” p. 100.](#)

If the waterboxes on any of the shells are exchanged end-for-end, be sure to reinstall them right side up to maintain the correct baffle arrangements. Use a new gasket with each waterbox cover.

Three-pass waterboxes have lifting lugs on the top and bottom. When reinstalling, ensure that the waterbox is oriented the same way it was removed.

Grooved Pipe Coupling

A customer-supplied, standard flexible grooved pipe coupling (Victaulic Style 77 or equivalent) should be used to complete the Victaulic connection for both 1034.2 kPaG or 150 psig and 2068.4 kPaG or 300 psig waterboxes.

When a flexible coupling such as this is installed at the waterbox connections, other flexible piping connectors (i.e., braided-steel, elastomeric arch, etc.) are usually not required to attenuate vibration and/or prevent stress on the connections.

Table 5. Water piping connection components

		Customer Piping Connection	
Unit Model	Unit Connection Type	Victaulic	Flanged
CVHH	Flanged (optional)	Customer provided	No adapter required
CVHH	Victaulic (all others)	Victaulic coupling	Trane provided Victaulic-to-flange adapter

Figure 15. Customer piping connection types

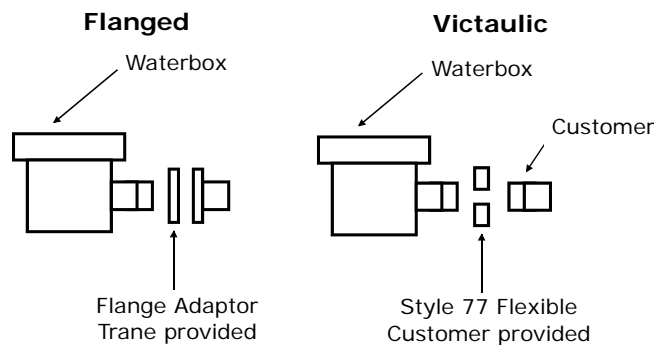

- Refer to the coupling manufacturer's guidelines for specific information concerning proper piping system design and construction methods for grooved water piping systems.
- Flexible coupling gaskets require proper lubrication before installation to provide a good seal. Refer to the coupling manufacturer's guidelines for proper lubricant type and application.

Flange-Connection Adapters

When flat-face flange connections are specified, flange-to-groove adapters are provided (Victaulic Style 741 for 1034.2 kPaG or 150 psig systems; Style 743 for 2068.4 kPaG or 300 psig systems). The adapters are shipped bolted to one of the chiller end-supports. Adapter descriptions are given in [Table 6, p. 28](#) and [Table 7, p. 28](#). The flange adapters provide a direct, rigid connection of

flanged components to the grooved-pipe chiller waterbox connections.

Figure 16. Typical shipping location for flange

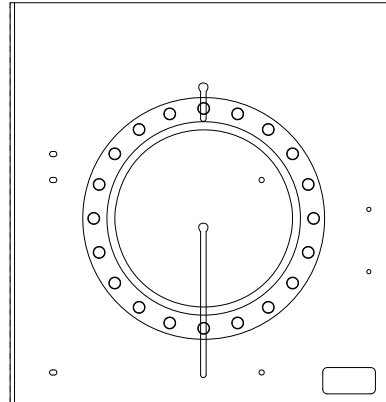

In this case, the use of flexible type connectors (i.e., braided steel, elastomeric arch, etc.) are recommended to attenuate vibration and prevent stress at the waterbox connections. Flange adapters are not provided for CVHH units with 2068.4 kPaG or 300 psig waterboxes that have 356 mm (14 in.) and larger piping connections.

All flange-to-flange assembly bolts must be provided by the installer. Bolt sizes and number required are given in [Table 6, p. 28](#) and [Table 7, p. 28](#). The four draw-bolts needed for the 355.6 mm (14 in.) and larger Style 741 (1034.2 kPaG or 150 psig) adapters are provided. The Style 741, 1034.2 kPaG or 150 psig flange adapter requires a smooth, hard surface for a good seal.

Connection to other type flange faces (i.e., raised, serrated, rubber, etc.) will require the use of a flange washer between the faces. Refer to the flange adapter manufacturer's guidelines for specific information.

The Style 743 (2068.4 kPaG or 300 psig) flange adapters are designed to mate with raised-face flanges. They can be used with flat-faced flanges; however, only if the raised projections on the outside face of the adapter are removed; see [Figure 17](#). The flange-adapter gasket must be placed with the color-coded lip on the pipe and the other lip facing the mating flange.

NOTICE:

Piping Connection Leaks!

Failure to provide effective seal could result in equipment or property-only damage. To provide effective seal, gasket contact surfaces of adapter must be free of gouges, undulations or deformities.

Figure 17. Modifying 300 psig or 21 bar flange adaptors for flat-faced flange application

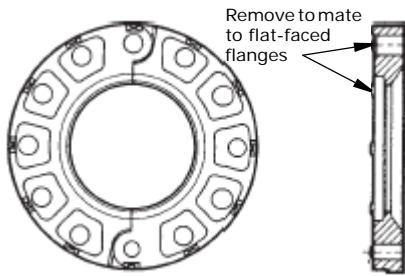
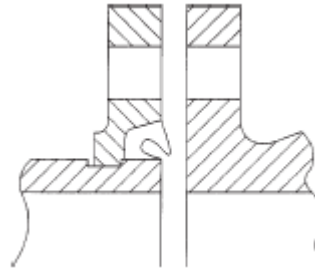

Figure 18. Typical Victaulic flange gasket configuration



Victaulic Gasket Installation

1. Inspect supplied gasket to be certain it is suited for intended service (code identifies gasket grade). Apply a thin coat of silicone lubricant to gasket tips and outside of gasket.
2. Install gasket, placing gasket over pipe end and making sure gasket lip does not overhang pipe end. Refer to [Figure 18](#) for gasket configuration.

3. Align and bring two pipe ends together and slide gasket into position centered between the grooves on each pipe. No portion of the gasket should extend into the groove on either pipe.
4. Open fully and place hinged Victaulic flange around the grooved pipe end with the circular key section locating into the groove.
5. Insert a standard bolt through the mating holes of the Victaulic flange to secure the flange firmly in the groove.
6. Tighten fasteners alternately and equally until housing bolt pads are firmly together (metal to metal); refer to [“Bolt-Tightening Sequence for Water Piping Connections,” p. 29](#). Do not excessively tighten fasteners.

Note: Uneven tightening may cause gasket to pinch.

Table 6. Installation data for 150 psig flange adaptors (Style 741)

Nominal Pipe Size		Assembly Bolt Size ^(a)	Number of Assembly Bolts Required	Bolt Pattern Diameter		Weight	
mm	in.	in.		mm	in.	kg	lb
200	8	3/4 x 3-1/2	8	298	11.75	7.5	16.6
250	10	7/8 x 4	12	362	14.25	11	24.2
300	12	7/8 x 4	12	432	17	21.2	46.8
350	14	1 x 4-1/2	12	476	18.75	28.1	62
400	16	1 x 4-1/2	16	540	21.25	35.8	79
450	18	1-1/8 x 4-3/4	16	578	22.75	37.3	82.3
500	20	1-1/8 x 5-1/4	20	635	25	46.9	103.3
600	24	1-1/4 x 5-3/4	20	749	29.5	64.4	142

(a) Bolt size for conventional flange to flange connection. Longer bolts are required when flange washer must be used.

Table 7. Installation data for 350 psig flange adaptors (Style 743)

Nominal Pipe Size		Assembly Bolt Size ^(a)	Number of Assembly Bolts Required	Bolt Pattern Diameter		Weight	
mm	in.	in.		mm	in.	kg	lb
219.1	8	3/4 x 4-3/4	12	330	13	15.6	34.3
273.0	10	1 x 5-1/4	16	387	15.25	21.9	48.3
323.9	12	1-1/8 x 5-3/4	16	451	17.75	32.0	70.5

(a) Bolt size for conventional flange to flange connection. Longer bolts are required when flange washer must be used.

Bolt-Tightening Sequence for Water Piping Connections

This section describes a bolt-tightening sequence for flanges with flat gaskets or O-rings. Remember that improperly tightened flanges may leak.

Note: Before tightening any of the bolts, align the flanges.

Flanges with 8 or 12 Bolts

Tighten all bolts to a snug tightness, following the numerical sequence for the appropriate bolt pattern as shown below. Repeat this sequence to apply the final torque to each bolt.

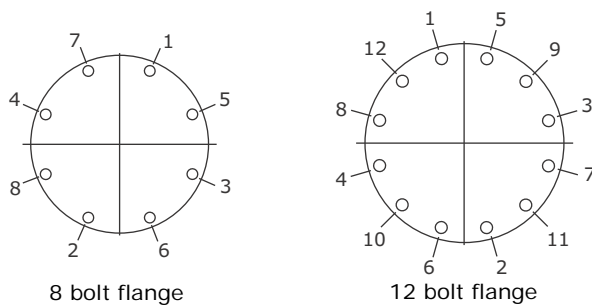

Flanges with 16 or 20 Bolts

Tighten only the first half of the total number of bolts to a snug tightness, following the numerical sequence for the appropriate bolt pattern as shown below. Next, sequentially tighten the remaining half of the bolts in numerical order.

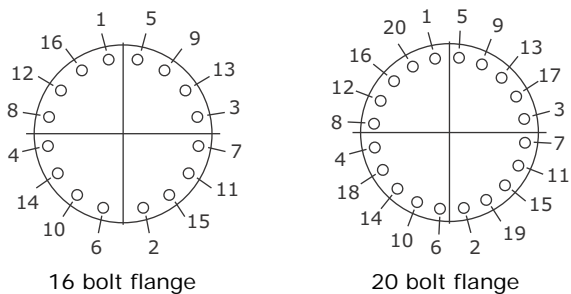

Pressure Testing Waterside Piping

NOTICE:

Equipment Damage!

Failure to follow these instructions could result in equipment damage. Do not over pressurize the system or exceed design pressure. Always perform as a hydro pressure test with water present in piping and waterboxes.

Waterside design pressure is either 1034.2 or 2068.4 kPaG (150 or 300 psig); refer to unit nameplate or to submittal documentation.



Vent Piping

Refrigerant Vent Line

General Requirements

State and local codes, and ASHRAE Standard 15 contain requirements for venting the relief device on the chiller to the atmosphere outside of the building. These requirements include, but are not limited to, permitted materials, sizing, and proper termination.

Note: The following information is a general outline of vent-line installation requirements based on ASHRAE Standard 15. Most codes contain similar requirements but may vary in some significant areas. The installer must check state and local codes and follow the specific requirements applicable to the location.

Purge Discharge

To comply with ASHRAE Standard 15, the discharge piping from purge units that remove noncondensable gas from refrigerating systems must conform to the ASHRAE Standard 15 requirements for relief piping. To help meet this requirement, the purge discharge is factory-piped to the relief device assembly.

Vent Line Materials

All materials in the relief device vent system must be compatible with the refrigerant in use. Commonly used and accepted piping materials include steel and DWV (drain/waste/vent) copper. Consult local codes for restrictions on materials. Consult with the manufacturers of any field-provided components or materials for acceptable material compatibility.

Note: PVC piping is acceptable for use as a vent line material with R-1233zd(E), but the glue that joins the sections of plastic pipe may not be. When considering a vent system constructed of plastic piping, such as PVC, ensure that both the pipe material and the adhesive have been tested for refrigerant compatibility. In addition, verify that the local codes permit PVC for refrigerant vent lines; even though ASHRAE Standard 15 doesn't prohibit its use, some local codes do.

The following materials for PVC pipe construction are recommended for use with R-1233zd(E):

Primer/Cleaner:

- Hercules—PVC Primer #60-465
- RECTORSEAL® PVC Cleaner—Sam™ CL-3L

Adhesives:

- Hercules—Clear PVC, Medium Body/Medium Set, #60-020
- RECTORSEAL—PVC Cement, Gene™ 404L

Vent Line Sizing

Vent line size must conform to local codes and requirements. In most cases, local codes are based on ASHRAE Standard 15. ASHRAE Standard 15 provides specific requirements for the discharge piping that allows pressure-relief devices to safely vent refrigerant to the atmosphere if over pressurization occurs. In part, the standard mandates that:

- The minimum pipe size of the vent line must equal the size of the discharge connection on the pressure-relief device. A larger vent line size may be necessary, depending on the length of the run.
- Two or more relief devices can be piped together *only if* the vent line is sized to handle all devices that could relieve at the same time.
- When two or more relief devices share a common vent line, the shared line must equal or exceed the sum of the outlet areas of all upstream relief devices, depending on the resulting back pressure.

ASHRAE Standard 15 provides guidance for determining the maximum vent line length. It also provides the equation (shown in [Figure 23, p. 36](#)) and data necessary to properly size the vent line at the outlet of a pressure-relief device or fusible plug.

The equation accounts for the relationship between pipe diameter, equivalent pipe length, and the pressure difference between the vent line inlet and outlet to help ensure that the vent line system provides sufficient flow capacity.

[Table 8, p. 35](#) provides additional information based on ASHRAE Standard 15, including:

- Capacities of various vent line sizes and lengths. However, this data applies only to conventional pressure-relief valves and NOT to balanced relief valves, rupture members (as used on Trane® centrifugal chillers), fusible plugs, or pilot-operated valves.
- A simplified method to determine the appropriate vent-line size, with [Figure 23, p. 36](#). Enter the figure with the total C value, read across to a pipe curve and down to find the maximum allowable length for that size pipe.

To determine the total C value for a specific unit, add the appropriate C values for the evaporator, standard condenser, and economizer. If the unit is equipped with any options (e.g., heat recovery, free cooling, or an auxiliary condenser), add the applicable C value(s) for those options to the total as well.

Note: [Table 8, p. 35](#) and [Figure 23, p. 36](#) are applicable only for non-manifolded vent-line runs connected to a 344.7 kPaG (50 psig) rupture disk relief device. The pipe length provided by the table is in "equivalent feet." The vent-line length in equivalent

feet is the sum of the linear pipe length plus the equivalent length of the fittings (e.g., elbows).

Vent Line Installation

Important: Before constructing the rupture disk vent line, consult local codes for applicable guidelines and constraints.

All CenTraVac centrifugal chillers are equipped with rupture disks. If refrigerant pressure within the evaporator exceeds 344.7 kPaG (50 psig) the rupture disk breaks and shell pressure is relieved as refrigerant escapes from the chiller.

A cross-section of the rupture disk assembly appears in [Figure 19, p. 33](#) along with an illustration indicating the location of the rupture disk on the suction elbow.

Several general recommendations for rupture disk vent line installation are outlined below.

Note: If the rupture disk was removed for service or vent line piping installation, the rupture disk must be reinstalled (as shown in [Figure 19, p. 33](#)). Refer to the following procedure and contact CenTraVac Technical Service when reinstalling the rupture disk.

- Verify that the rupture disk is positioned as shown in the cross-section view that appears in [Figure 19, p. 33](#).
 - Install the two bottom bolts through the pipe flanges.
 - Install the rupture disk with a gasket on each side between the pipe flanges. Orient the disk with the reference arrow facing the chiller side as shown in [Figure 19, p. 33](#).
 - Install the two top bolts.
 - Center the disk and gaskets to the flange bore.
 - Hand tighten all bolts assuring equal pressure.
 - Use a torque wrench set to 196.6 N·m (145 ft·lb) with a 24-mm socket.
 - Tighten bolts in a star pattern, one half turn each, to maintain even pressure on the disk.
 - Final torque on all bolts should be 196.6 N·m (145 ft·lb).
- When attaching the vent line to the chiller, do not apply threading torque to the outside pipe of the rupture disk assembly.

the rupture disk. (Stress can alter rupture pressure and cause the disk to break prematurely.) The flexible connector used to isolate the rupture disk from excessive vent line vibration must be compatible with the refrigerant in use. Use a flexible, steel connector such as the stainless-steel type MFP, style HNE, flexible pump connector (from Vibration Mounting and Control, Inc.) or equivalent. Refer to [Figure 20, p. 34](#) for a recommended relief piping arrangement.

⚠ WARNING

Pressure-Relief Device Discharge Hazard!

An improper vent-line termination could result in death or serious injury or equipment damage. When a pressure-relief device operates, it could discharge a large amount of fluid and/or vapor. Units **MUST** be equipped with a vent-line termination that discharges outdoors in an area that will not spray refrigerant on anyone.

NOTICE:

Rupture Disk Damage!

Failure to follow instruction could result in damage to the rupture disk assembly. Do not apply threading torque to the outside pipe.

- Provide support as needed for the vent line. Do not use the rupture disk assembly to support the vent line piping.
- Use a flexible connection between the vent-line and the rupture disk assembly to avoid placing stress on

NOTICE:
Proper Refrigerant Vent Line Termination!

Failure to properly terminate a refrigerant vent line could result in equipment damage. Improperly terminating a refrigerant vent line could allow rain to enter the line. Accumulated rainwater could cause the relief device to malfunction; or, in the case of a rupture disk, the rainwater pressure could cause the disk to rupture, allowing water to enter the chiller.

NOTICE:
Equipment Damage!

Trane assumes no responsibility for equipment damage caused by insufficient drainage of the drip leg. All vent-lines must be equipped with a drip leg of sufficient volume to hold the expected accumulation of water and or refrigerant. The drip leg must be drained periodically to ensure that it does not overflow and allow fluid to flow into the horizontal portion of the vent-line.



Note: Graphic labels (shown above) are used for CE application only.

- Route the vent-line piping so that it discharges outdoors in an area that will not spray refrigerant on anyone. Position the vent line discharge at least 4.572 meters (15 feet) above grade level and at least 6.096 meters (20 feet) from any building opening. Provide a vent line termination that cannot be blocked by debris or accumulate rainwater.
- Provide a drip leg on the vent-line (see [Figure 20, p. 34](#)). Provide a standard 1/4-in. FL x 1/4-in. NPT, capped refrigerant service valve to facilitate liquid removal.

- Consult local regulations and codes for any additional relief line requirements.

Figure 19. Illustrates rupture disk location, cross section of rupture disk

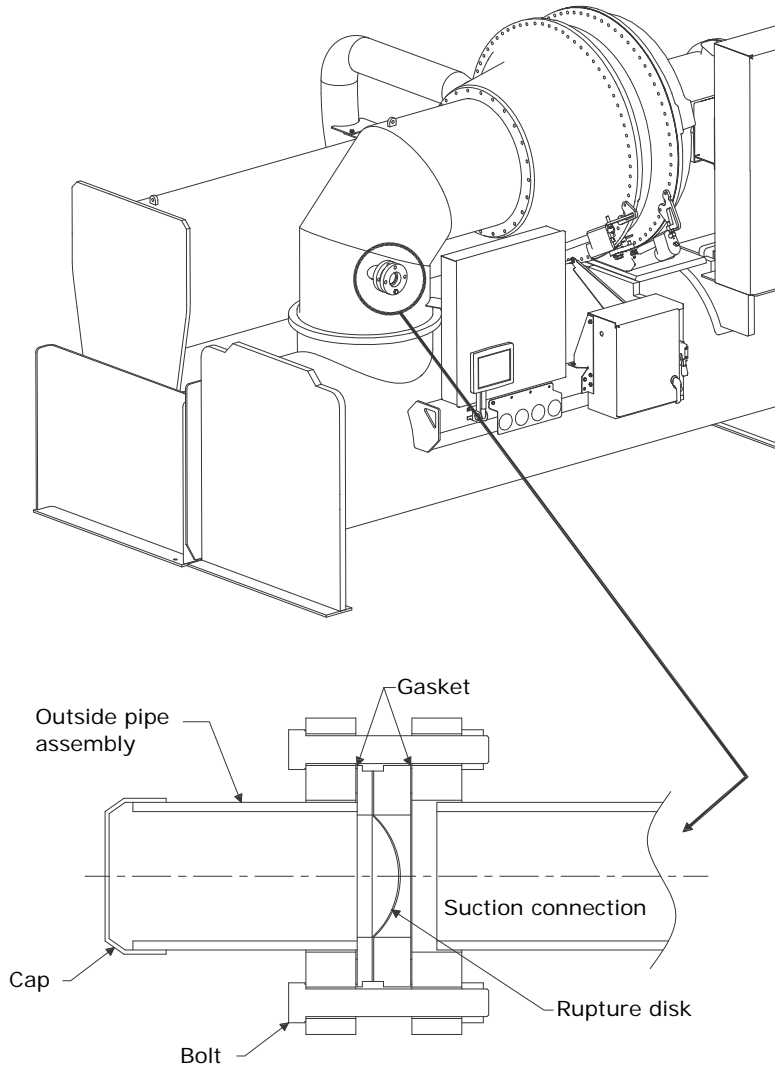

Note: Pipe connection is 3 in. NPT.

Figure 20. Arrangement for rupture disk relief piping

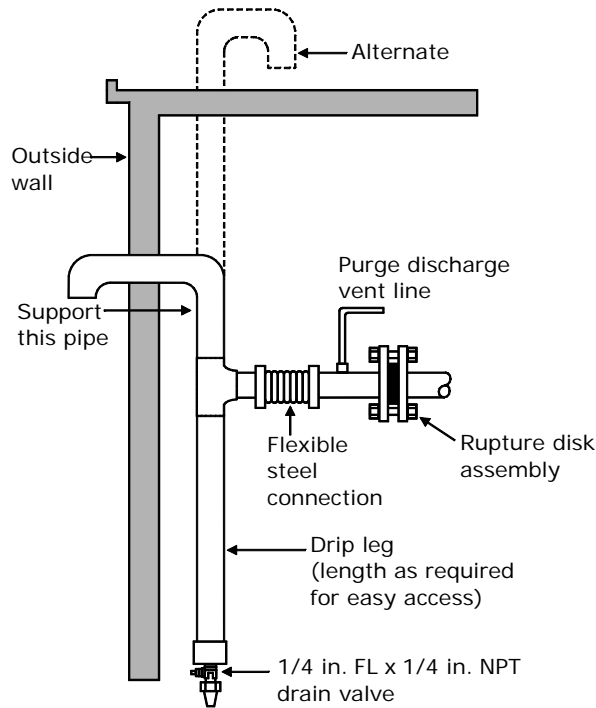

Trane RuptureGuard

General Information

The Trane RuptureGuard™ refrigerant containment system replaces the rupture disk on new low pressure chillers utilizing R-1233zd(E). The RuptureGuard system consists of a solid-metal, (non-fragmenting) reverse-buckling rupture disk, and automatically re-seating relief valve. The relief valve and the rupture disk are rated at the chiller's maximum working pressure level. If the chiller's refrigerant pressure exceeds the rupture disk burst rating, the disk bursts, releasing pressure to the relief valve. The relief valve vents the pressure down to a safe level and then re-seats, thus minimizing the amount of refrigerant vented to the atmosphere. Figure 21 illustrates the operation of a reverse buckling rupture disk.

Figure 21. Reverse buckling rupture disk

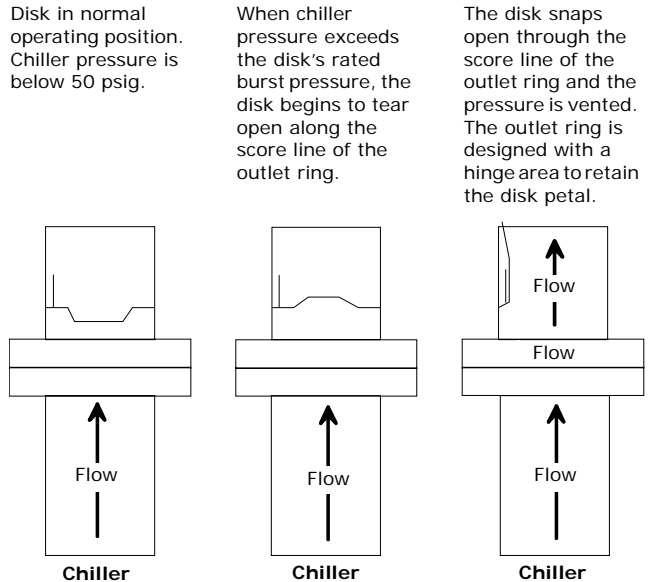

To prevent water, refrigerant and/or other debris such as rust from hindering the operation of the valve, a drip leg should be installed immediately after or downstream of the RuptureGuard (see Figure 22).

Connection to External Vent Line and Drip Leg

NOTICE:

Equipment Damage!

Trane assumes no responsibility for equipment damage caused by insufficient drainage of drip leg. All vent lines must be equipped with a drip leg of sufficient volume to hold the expected accumulation of water and/or refrigerant. The drip leg must be drained periodically to assure that it does not overflow and allow fluid to flow into the horizontal portion of the vent line.

With RuptureGuard installed horizontally, the drain plug downstream of the valve relief plug and nearest to the bottom of the valve body should be piped to the drip leg in the vent line. This will allow the removal of any condensate formed within the valve body.

Provisions, such as installing a set of flanges (see Figure 22) or other disconnect means, must be made in the discharge vent piping. This will allow the piping downstream of the valve to be easily removed for an annual inspection, to replace the rupture disk, or for any other servicing need.

Figure 22. External vent line and drip leg (not provided)

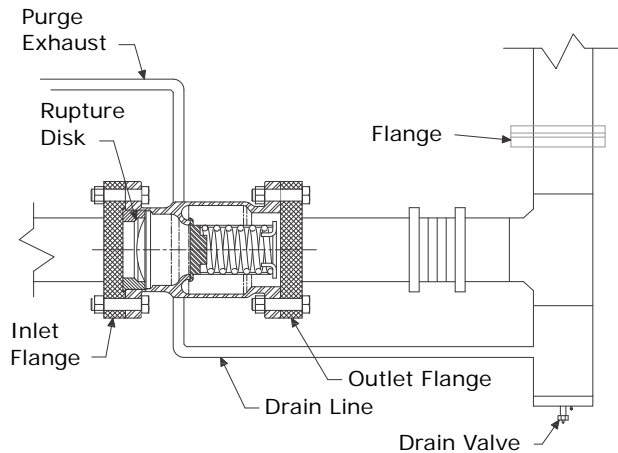

Connect the discharge of the valve assembly to the vent line connected to the outdoors.

Note: Make sure there are no crosses¹, elbows, tees or any other obstructions within the first 22.86 cm (9 in.) of valve discharge. Refer to ASHRAE Standard 15, national, state, and local codes for additional requirements on piping rupture disk and relief valve vent lines.

Table 8. "C" values used to determine rupture disk vent line sizes (kg/s); for use with Figure 23, p. 36

NTON	"C" Values for Unit Components						
	Evap. Size (EVSZ)	Cond. Size (CDSZ)	Total "C" Value	Evap.	Cond.	Econ.	Oil Tank
900-1200	100M	100M	0.853	0.368	0.310	0.141	0.034
900-1200	100L	100L	0.939	0.415	0.349	0.141	0.034
900-1200	130M	130M	0.932	0.412	0.346	0.141	0.034
900-1200	160M	200M	1.022	0.461	0.386	0.141	0.034
900-1200	200L	220L	1.222	0.575	0.473	0.141	0.034
900-1200	220L	220L	1.284	0.637	0.473	0.141	0.034
1500-1700	200L	200L	1.195	0.575	0.435	0.151	0.034
1500-1700	220L	220L	1.295	0.637	0.473	0.151	0.034
900-1200	100M	10HM	0.967	0.368	0.424	0.141	0.034
900-1200	130M	13HM	1.053	0.412	0.467	0.141	0.034
900-1200	160M	20HM	1.144	0.461	0.509	0.141	0.034
1500-1700	200L	20HL	1.332	0.575	0.573	0.151	0.034
1500-1700	220L	22HL	1.458	0.637	0.637	0.151	0.034

Notes:

1. Rupture disk diameter is 76.2 mm (3 in.).
2. Use the total "C" value in Figure 23, p. 36 to determine the vent line pipe diameter.
3. If piping multiple rupture disks (multiple units) to a common vent line, first determine the total "C" value for each unit, and then; add all "C" values together and apply the result to Figure 23, p. 36.
4. The CVHH unit is a Simplex chiller and has (1) refrigerant circuit and (1) relief device.

¹ A derate on the rated flow capacity for this configuration is published in RuptureGuard engineering bulletin, E/CTV-EB-10.

Figure 23. Rupture disk vent pipe sizing (SI units); for use with [Table 8, p. 35](#)

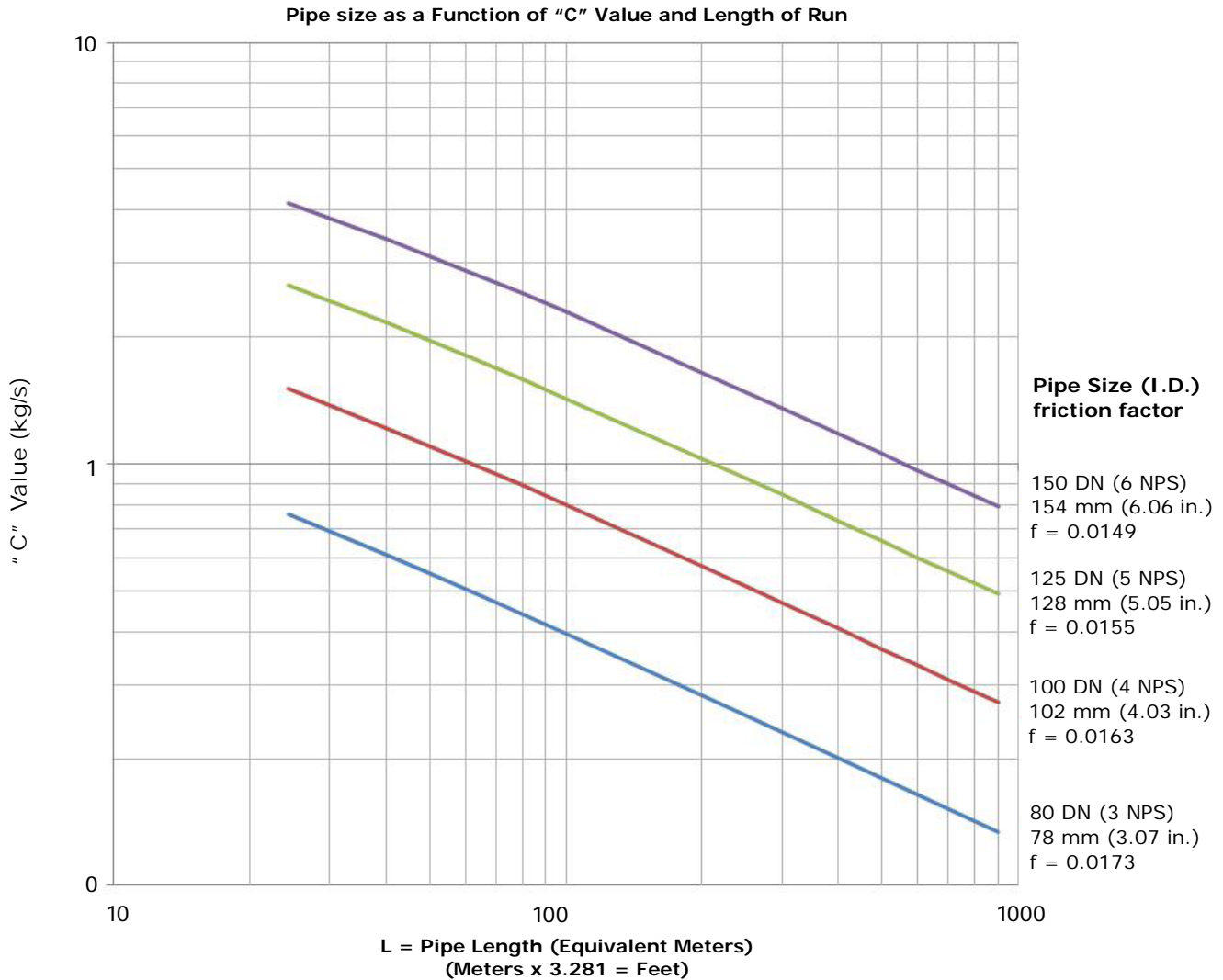

ASHRAE Standard 15

$$L = \frac{7.4381 \times 10^{-15} d^5 (P_0^2 - P_2^2)}{f C_R^2} - \frac{d \cdot \ln(P_0 / P_2)}{500f}$$

Note: This figure, provided as a reference, is based on ASHRAE Standard 15. Vent line size is typically dictated by state or local code which may be different from ASHRAE Standard 15 requirements.

- L = equivalent length of discharge piping, meters
- C_R = rated capacity as stamped on the relief device in SCFM (conversion: kg/s = SCFM * 0.0764 / 132.28)
 C_R = C value from [Table 8, p. 35](#) (convert C in kg/s to lb/min for IP; lb/min = (kg/s) / 132.28)
- f = Moody friction factor in fully turbulent flow
- d = inside diameter of pipe or tube, mm
- \ln = natural logarithm
- P_2 = absolute pressure at outlet of discharge piping, kPa (atmospheric pressure)
- P_0 = allowed back pressure (absolute) at the outlet of pressure relief device, kPa
 $P_0 = (0.15 P) + \text{atmospheric pressure}$

Table 9. "C" values used to determine rupture disk vent line sizes (lb/min); for use with [Figure 24, p. 38](#)

NTON	Evap. Size (EVSZ)	Cond. Size (CDSZ)	"C" Values for Unit Components				Oil Tank
			Total "C" Value	Evap.	Cond.	Econ.	
900-1200	100M	100M	112.0	48.4	40.7	18.5	4.5
900-1200	100L	100L	123.2	54.5	45.8	18.5	4.5
900-1200	130M	130M	122.4	54.0	45.4	18.5	4.5
900-1200	160M	200M	134.1	60.5	50.7	18.5	4.5
900-1200	200L	220L	160.4	75.4	62.1	18.5	4.5
900-1200	220L	220L	168.6	83.6	62.1	18.5	4.5
1500-1700	200L	200L	156.8	75.4	57.1	19.8	4.5
1500-1700	220L	220L	169.9	83.6	62.1	19.8	4.5
900-1200	100M	10HM	127.0	48.4	55.7	18.5	4.5
900-1200	130M	13HM	138.2	54.0	61.3	18.5	4.5
900-1200	160M	20HM	150.2	60.5	66.8	18.5	4.5
1500-1700	200L	20HL	174.9	75.4	75.2	19.8	4.5
1500-1700	220L	22HL	191.4	83.6	83.6	19.8	4.5

Notes:

1. Rupture disk diameter is 3 in. (76.2 mm).
2. Use the total "C" value in [Figure 24, p. 38](#) to determine the vent line pipe diameter.
3. If piping multiple rupture disks (multiple units) to a common vent line, first determine the total "C" value for each unit, and then; add all "C" values together and apply the result to [Figure 24, p. 38](#).
4. The CVHH unit is a Simplex chiller and has (1) refrigerant circuit and (1) relief device.

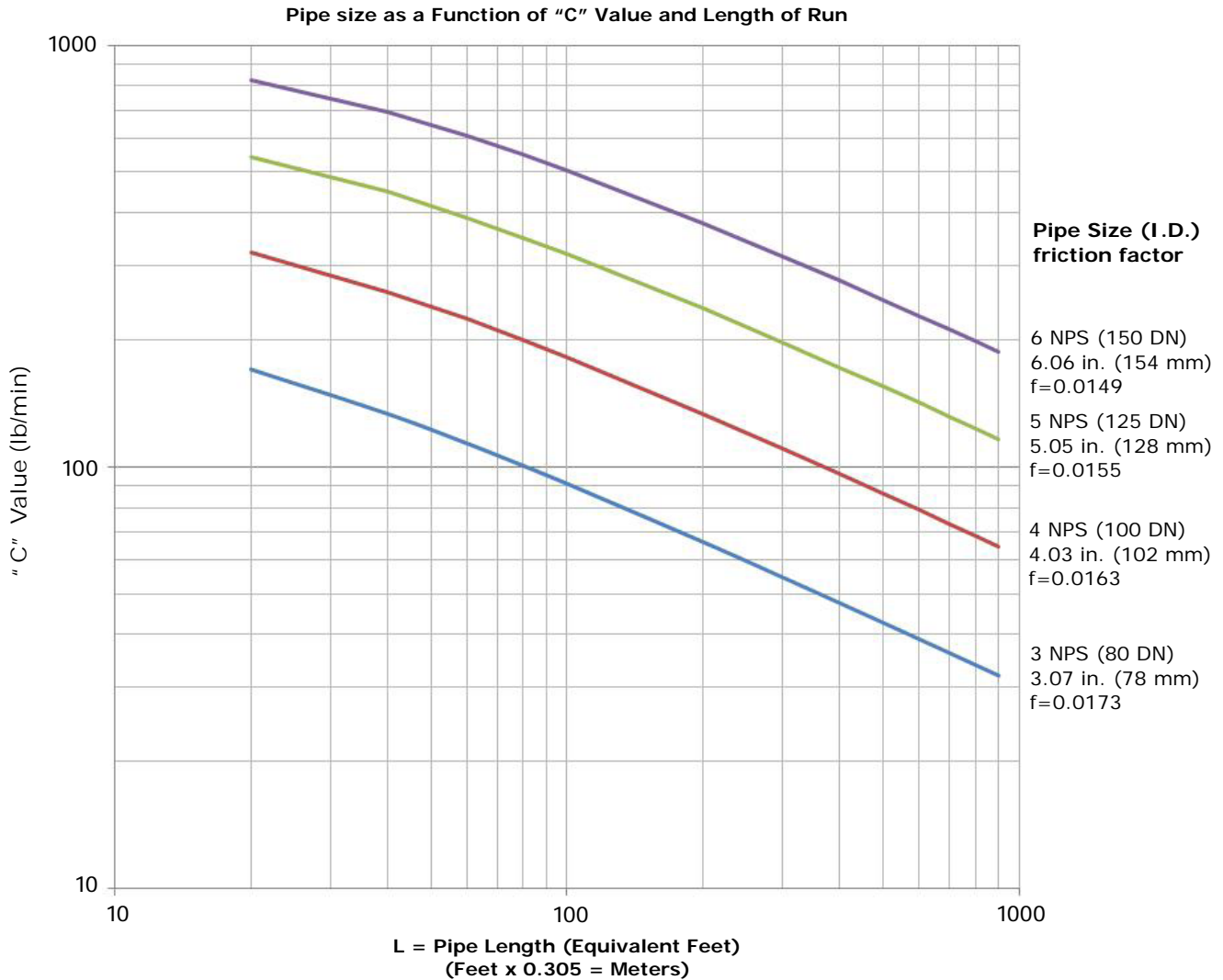
Figure 24. Rupture disk vent pipe sizing (IP units); for use with [Table 9, p. 37](#)

ASHRAE Standard 15

$$L = \frac{0.214d^5 (P_2^2 - P_0^2)}{fC_R^2} - \frac{d * \ln(P_0 / P_2)}{6f}$$

Note: This figure, provided as a reference, is based on ASHRAE Standard 15. Vent line size is typically dictated by state or local code which may be different from ASHRAE Standard 15 requirements.

- L = equivalent length of discharge piping, feet
- C_R = rated capacity as stamped on the relief device in SCFM (conversion: lb/min = SCFM * 0.0764)
 C_R = C value in lb/min from [Table 9, p. 37](#)
- f = Moody friction factor in fully turbulent flow
- d = inside diameter of pipe or tube, in.
- \ln = natural logarithm
- P_2 = absolute pressure at outlet of discharge piping, psi (atmospheric pressure)
- P_0 = allowed back pressure (absolute) at the outlet of pressure relief device, psi
 $P_0 = (0.15 P) + \text{atmospheric pressure}$



Insulation

Unit Insulation Requirements

Factory-installed insulation is available as an option for all units. Factory installation does not include insulation of the chiller feet; if required, insulation for chiller feet is provided by others. In applications where the chiller is not factory-insulated, install insulation over the areas outlined and highlighted with dashed lines as shown in [Figure 25, p. 40](#).

Insulate all 6.35-mm (1/4-in.) eductor lines, one from the suction cover and one from the evaporator to prevent sweating.

The quantities of insulation required based on unit size and insulation thickness are listed in [Table 10](#). Insulation thickness is determined at normal design conditions which are:

- standard comfort-cooling leaving chilled water temperature
- 29.4°C (85°F) dry bulb ambient temperature
- 75 percent relative humidity

Operation outside of normal design conditions as defined above may require additional insulation; contact Trane for further review.

Note: If the unit is not factory-insulated: install insulation around the evaporator bulbwells and ensure that the bulbwells and connections for the waterbox drains and vents are still accessible after insulation is applied. The sensor modules (LLIDs) and interconnecting four wire cable (IPC bus) must be raised up above the field-installed insulation. Secure the IPC bus to the insulation top/outer surface after insulation is completed.

Important: Do not insulate the motor housing, unit wiring, or sensor modules.

⚠ WARNING

Replace Manual in Cabinet After Use!

Failure to replace this Installation, Operation, and Maintenance manual in cabinet after use could prevent personnel from accessing necessary safety information and could result in death or serious injury or equipment damage.

NOTICE:

Equipment Damage!

Failure to remove the strain relief with the sensor could result in equipment damage. Do NOT attempt to pull sensor bulb through the strain relief; always remove the entire strain relief with the sensor.

Table 10. CVHH evaporator insulation requirements

EVSZ (Standard Unit)	190.5 mm (3/4 in.) Insulation	
	m ²	ft ²
100M	61.4	661
100L	63.2	680
130M	63.5	684
160M	66.1	711
200M	68.6	738
200L	71.1	765
220M	71.5	770
220L	74.2	799

Notes:

1. Units are NOT insulated on the motor or refrigerant drain lines.
2. 19.05-mm (3/4-in.) sheet insulation is installed on the evaporator, evaporator waterboxes, suction elbow, suction cover, economizer, liquid lines, and piping.
3. Copper oil eductor lines require pipe insulation.

Insulation Thickness Requirements

Factory applied insulation. All low-temperature surfaces are covered with 19.05 mm (3/4 in.) Armaflex® II or equal (thermal conductivity = 0.036 W/m²-K [0.25 Btu/h-ft²]), including the evaporator, waterboxes, suction elbow, economizer, and piping.

The insulation is Armaflex or equivalent closed cell elastomeric insulation to prevent the formation of condensation in environments with a relative humidity up to 75%. Chillers in high humidity areas or ice storage, low leaving water temperature (less than 2.2°C [36°F] chilled water temperature/glycol) units may require double thickness to prevent formation of condensation.

NOTICE:

Insulation Damage!

To prevent damage to factory installed insulation:

- Do not allow the insulation to be exposed to excessive sunlight. Store indoors or cover with canvas to prevent exposure.
- Do not use thinners and solvents or other types of paint. Use only water base latex.

Failure to follow these instructions could result in insulation damage.

Figure 25. Recommended area for unit insulation

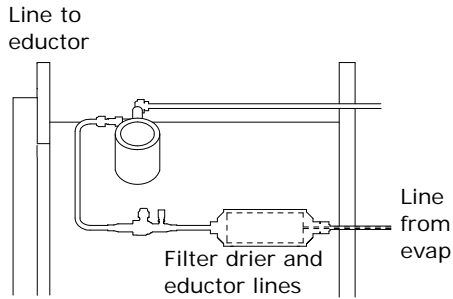

Notes:

1. Bulbwells, drain and vent connections must be accessible after insulating.
2. Evaporators with pressure vessel nameplates must have insulation cut out around the nameplate. Do not glue insulation to the nameplate.
3. All units with evaporator marine waterboxes wrap waterbox shell insulation with strapping and secure strapping with seal.
4. Apply 50.8-mm (2-in.) wide black tape on overlap joints. Where possible apply 7.6-cm (3-in.) wide strip of 9.7-mm (0.38-in.) thick insulation over butt joint seams.
5. Insulate all economizer supports.

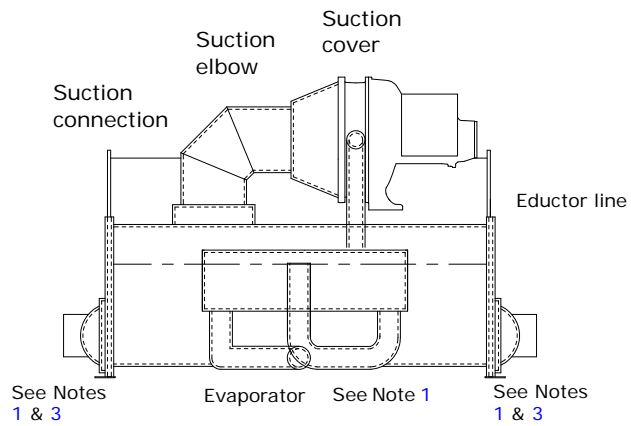
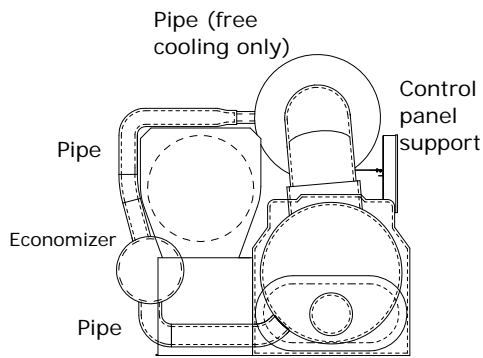



Installation: Controls

This section covers information pertaining to the UC800 controller hardware. For information about the Tracer AdaptiView™ display, which is used to interface with the internal chiller data and functions provided by the UC800, refer to *Tracer AdaptiView™ Display for Water-Cooled CenTraVac™ Chillers Operations Guide* (CTV-SVU01*-EN, or the most recent version).

UC800 Specifications

Power Supply

NOTICE:

Customer Wiring!
 Failure to follow instructions below could result in equipment or property-only damage. Only use flexible conduit or metal-clad cable when wiring the control panel and motor terminal box to ensure a vibration-free installation.

The UC800 (1K1) receives 24 Vac (210 mA) power from the 1T3 power supply located in the chiller control panel.

Wiring and Port Descriptions

Figure 26 illustrates the UC800 controller ports, LEDs, rotary switches, and wiring terminals. The numbered list following Figure 26 corresponds to the numbered callouts in the illustration.

Figure 26. Wiring locations and connection ports

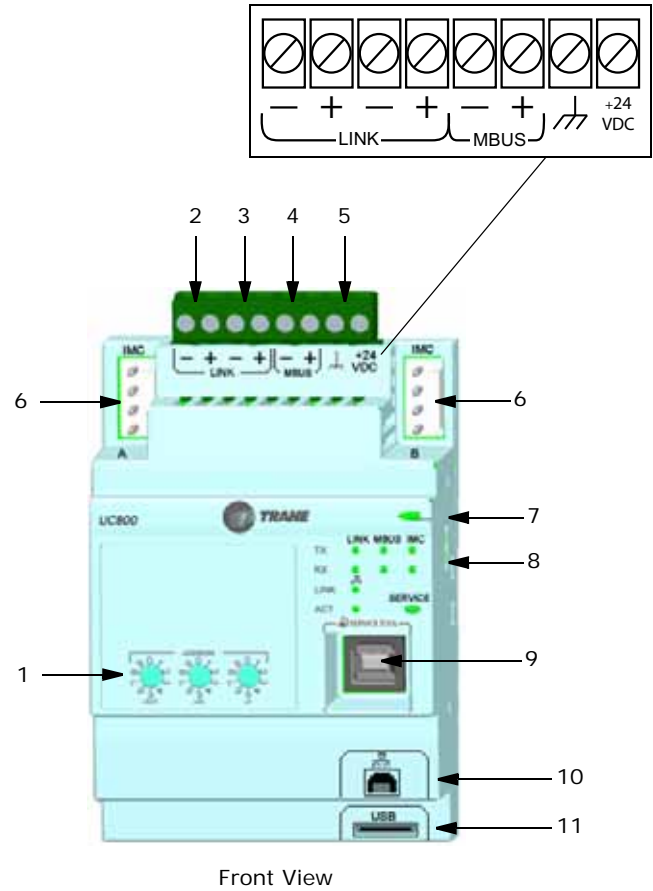
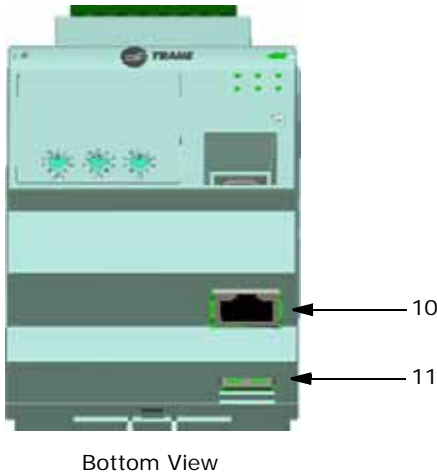

Figure 26. Wiring locations and connection ports



1. Rotary Switches for setting BACnet® MAC address or MODBUS® ID.
2. LINK for BACnet MS/TP, or MODBUS Slave (two terminals, ±). Field wired if used.
3. LINK for BACnet MS/TP, or MODBUS Slave (two terminals, ±). Field wired if used.
4. Machine bus for existing machine LLIDs (IPC3 Tracer bus 19,200 baud). *IPC3 Bus: used for Comm4 using TCI or LonTalk® using LCI-C.*
5. Power (210 mA at 24 Vdc) and ground terminations (same bus as item 4). Factory wired.
6. Not used.
7. Marquee LED power and UC800 Status indicator (Table 11, p. 42).
8. Status LEDs for the BAS link, MBus link, and IMC link.
9. USB device type B connection for the service tool (Tracer TU).
10. The Ethernet connection can *only* be used with the Tracer AdaptiView display.
11. USB Host (not used).

Communication Interfaces

There are four connections on the UC800 that support the communication interfaces listed. Refer to Figure 26, p. 41 for the locations of each of these ports.

- BACnet MS/TP
- MODBUS Slave
- LonTalk using LCI-C (from the IPC3 bus)
- Comm 4 using TCI (from the IPC3 bus)

Rotary Switches

There are three rotary switches on the front of the UC800 controller. Use these switches to define a three-digit address when the UC800 is installed in a BACnet or MODBUS system (e.g., 107, 127, etc.).

Note: Valid addresses are 001 to 127 for BACnet and 001 to 247 for MODBUS.

LED Description and Operation

There are 10 LEDs on the front of the UC800. Figure 27 shows the locations of each LED and Table 11, p. 42 describes their behavior in specific instances.

Figure 27. LED locations

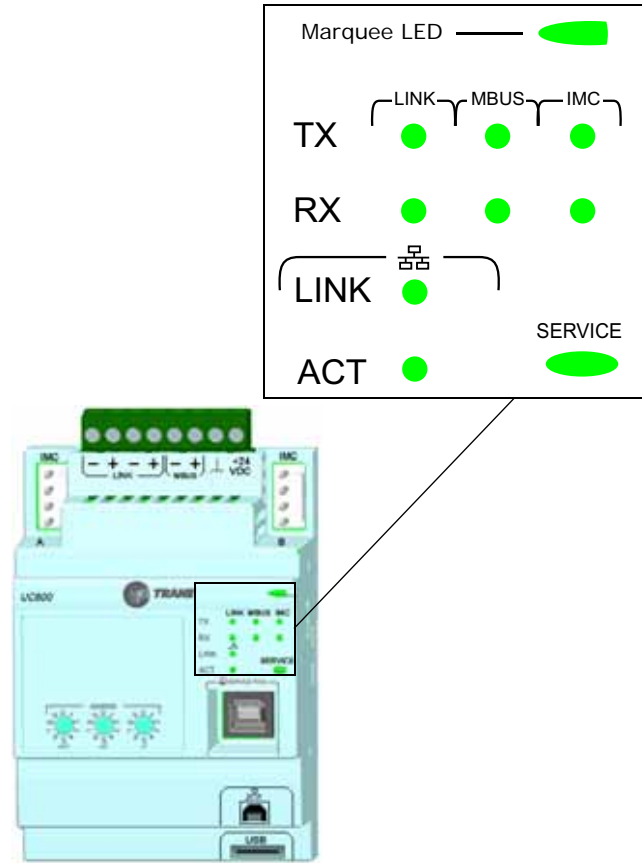
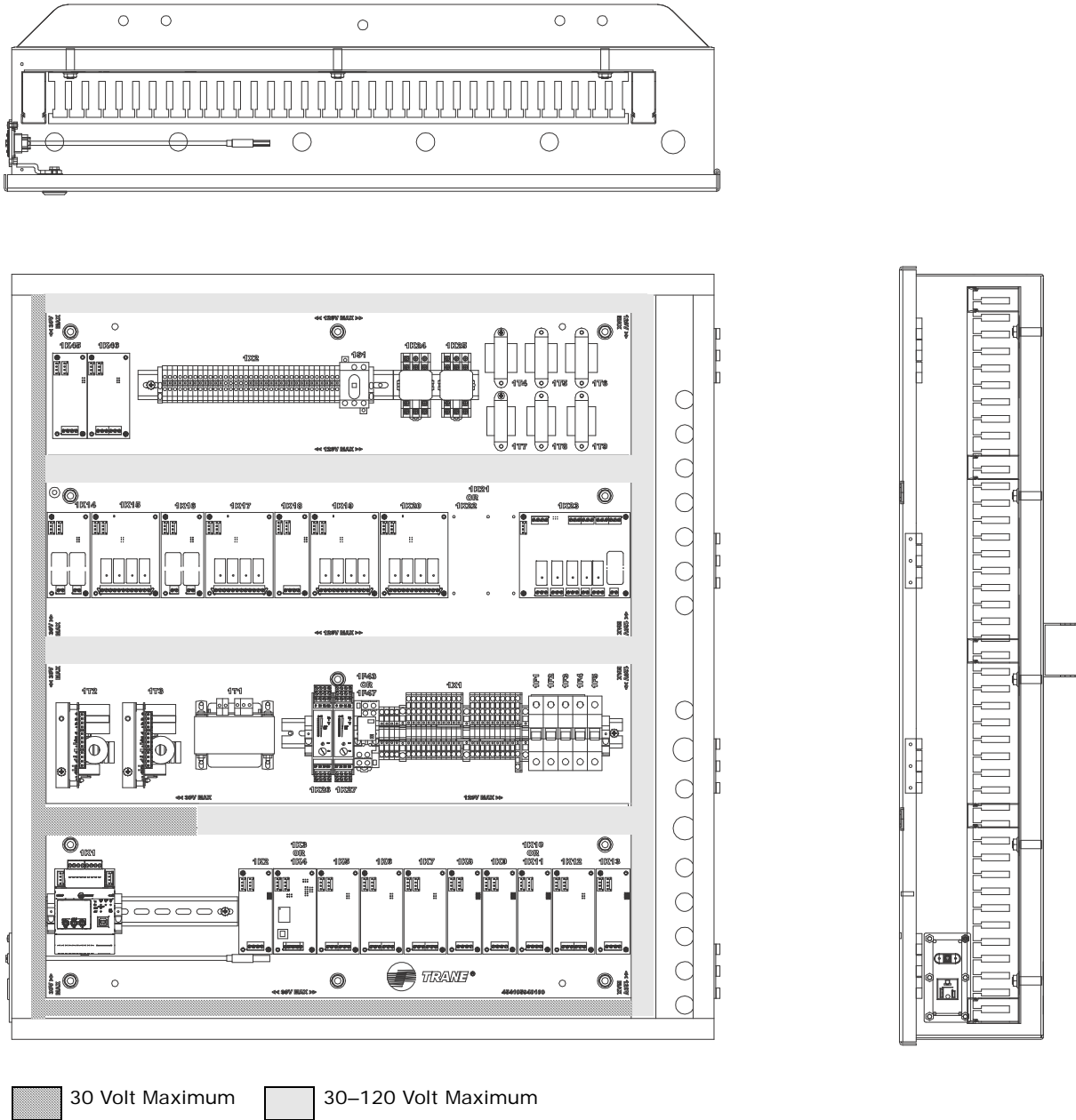

Table 11. LED behavior

LED	UC800 Status
Marquee LED	Powered. If the Marquee LED is green solid, the UC800 is powered and no problems exist.
	Low power or malfunction. If the Marquee LED is red solid, the UC800 is powered, but there are problems present.
	Alarm. The Marquee LED blinks Red when an alarm exists.
LINK, MBUS, IMC	The TX LED blinks green at the data transfer rate when the UC800 transfers data to other devices on the link.
	The Rx LED blinks yellow at the data transfer rate when the UC800 receives data from other devices on the link.
Ethernet Link	The LINK LED is solid green if the Ethernet link is connected and communicating.
	The ACT LED blinks yellow at the data transfer rate when data flow is active on the link.
Service	The Service LED is solid green when pressed. For qualified service technicians only. Do not use.

Important: *Maintain at least 16 cm (6 in.) between low-voltage (<30V) and high voltage circuits. Failure to do so could result in electrical noise that could distort the signals carried by the low-voltage wiring, including IPC.*

Figure 28. Control panel: Tracer AdaptiView main unit assembly (showing low voltage and higher voltage areas for proper routing of field wiring)



Installing the Tracer AdaptiView Display

The Tracer AdaptiView display is boxed, shrink-wrapped, and located behind the control panel during shipment. The Tracer AdaptiView display must be installed at the site.

Important: The Tracer AdaptiView display and display arm are to be installed by Trane, or an agent of Trane, for best results.

1. Unwrap the control panel and display arm. Locate the box containing the Tracer AdaptiView display behind the control panel (labeled A).
2. After the box containing the display has been removed, remove the shipping bracket from the back of the control panel (B).

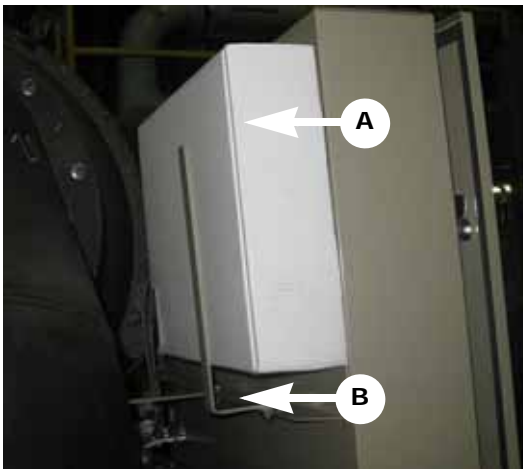

3. Remove the Tracer AdaptiView display from the box.
Note: Screws are M4 (metric size 4), 6 to 8 mm long, and are shipped with the display.
4. Plug the power cable (C) and the Ethernet cable (D) into the bottom of the display.
Note: Both cables are already present and extend from the end of the display arm.

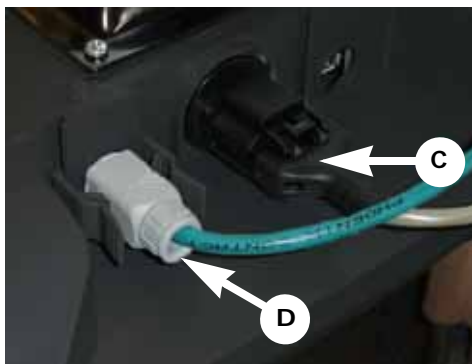

5. Adjust the Tracer AdaptiView display support arm so the base plate that attaches to the Tracer AdaptiView display is horizontal.

⚠ CAUTION

Tension in Display Support Arm!

Failure to ensure that the support arm is in the full upright position when removing the Tracer AdaptiView display from the support arm could result in unexpected movement of the spring-loaded support arm which could result in personal injury.

Note: Review "Adjusting the Tracer AdaptiView Display Arm," p. 45 prior to attaching the display as some adjustments may be required prior to attaching the display to the support arm base.

6. Position the Tracer AdaptiView display, with the LCD screen facing up, on top of the display support arm base plate.

Note: Ensure the Trane logo is positioned so that it will be at the top when the Tracer AdaptiView display is attached to the display support arm.

NOTICE:

Do Not Drop Display!

Failure to keep a firm grip on the Tracer AdaptiView display as you position the display on top of the support arm base plate could result in equipment or property-only damage.

7. Align the four holes in the display with the bolt holes in the display support arm base plate.
8. Attach the Tracer AdaptiView display to the display support arm base plate (E) using the M4 (metric size 4) screws referenced in [Step 3](#).



Adjusting the Tracer AdaptiView Display Arm

The Tracer AdaptiView display arm may become too loose or too tight and need adjustment. There are three joints on the display arm that allow the Tracer AdaptiView display to be positioned at a variety of heights and angles (refer to items labeled 1, 2, and 3 in [Figure 29](#)).

To adjust the tension on the display arm:

- At each joint in the display arm, there is either a hex bolt (1 and 2) or hex screw (3). Turn the hex bolt or screw in the proper direction to increase or decrease tension.

Note: Each hex bolt or screw is labeled with loosen/tighten or +/- indicators.

Figure 29. Joint locations on the display arm

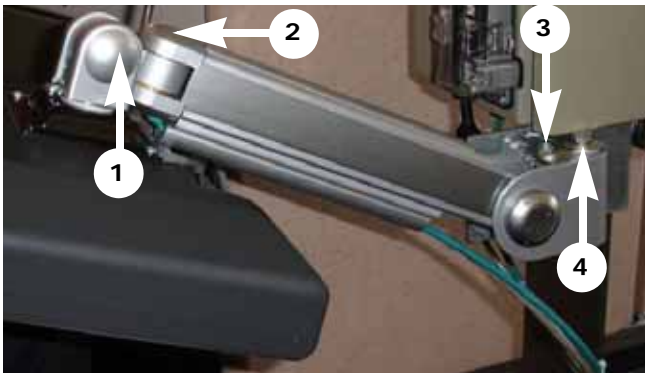

- Joint 3 has a 6 mm hex screw controlling the tension on a gas spring, which allows the Tracer AdaptiView display to tilt up and down.
- Joints 1 and 2 are covered by a plastic cap. Remove the plastic cap to access the hex bolt. Adjust using a 13 mm wrench as necessary.
- To adjust the swivel rotation tension of the Tracer AdaptiView display, adjust the hex bolt located in the support arm base plate, as described in [Step 8](#) in “[Installing the Tracer AdaptiView Display](#),” p. 44. This adjustment must be done prior to attaching the Tracer AdaptiView display to the support arm base. Use a 14 mm wrench to adjust the tension.
- To adjust the left/right swivel of the entire display arm, use a 13 mm wrench to adjust the bolt labeled 4 in [Figure 29](#).

Electrical Requirements

Installation Requirements

⚠ WARNING

Proper Field Wiring and Grounding Required!

Failure to follow code could result in death or serious injury. All field wiring **MUST** be performed by qualified personnel. Improperly installed and grounded field wiring poses **FIRE** and **ELECTROCUTION** hazards. To avoid these hazards, you **MUST** follow requirements for field wiring installation and grounding as described in **NEC** and your local/state/national electrical codes.



Note: Graphic labels (shown above) are used for CE application only.

Important:

- Before servicing, disconnect all power sources and allow at least 30 minutes for capacitors to discharge.
- All electrical enclosures—unit or remote—are IP2X.

Unit-mounted starters are available as an option on most units. While this option eliminates most field-installed wiring requirements, the electrical contractor must still complete the electrical connection for the following:

- power supply wiring to the starter,
- other unit control options present, and
- any field-supplied control devices.

As you review this manual, along with the wiring instructions presented in this section, keep in mind that:

- All field-installed wiring must conform to National Electric Code (NEC) guidelines, and any applicable national, state, and local codes. For the USA, be sure to satisfy proper equipment grounding requirements per NEC.
- Compressor motor and unit electrical data (including motor kW, voltage utilization range, rated load amps, and locked rotor amps) is listed on the chiller nameplate.
- All field-installed wiring must be checked for proper terminations, and for possible shorts or grounds.

Note: Always refer to the actual wiring diagrams that shipped with the chiller or the unit submittal for specific as-built electrical schematic and connection information.

NOTICE:

Starter Component Damage!

Failure to remove debris from inside the starter panel could result in an electrical short and could cause serious starter component damage.

Do not modify or cut enclosure to provide electrical access. Removable panels have been provided, and any modification should be done away from the enclosure. If the starter enclosure must be cut to provide electrical access, exercise care to prevent debris from falling inside the enclosure. Refer to installation information shipped with the starter or submittal drawings.

Electrical Requirements

Before wiring begins, observe the following electrical requirements:

- Follow all lockout-tagout procedures prior to performing installation and/or service on the unit.
- Always wear appropriate personal protective equipment.
- Wait the required time to allow the capacitor(s) to discharge; this could be up to 30 minutes.
- Verify that all capacitors are discharged prior to service using a properly rated volt meter.
- Use appropriate capacitor discharge tool when necessary.
- Comply with the safety practices recommended in PROD-SVB06*-EN.

For AWG/MCM equivalents in mm², refer to [Table 12](#):

Table 12. Wire sizing reference

AWG/MCM	mm ² equivalent
22	0.32
21	0.35
20	0.5
18	0.75
17	1.0
16	1.5
14	2.5
12	4
10	6
8	10
6	16
4	25
2 or 1	35
1/0	50
2/0	70
2/0 or 3/0	95
4/0 or 250	120
300	150
350 or 400	185
450 or 500	240

Note: AWG = American Wire Gauge

Important: Customers are responsible for all field wiring in compliance with local, national, and/or international codes.

⚠ WARNING

Hazardous Voltage w/Capacitors!

Failure to disconnect power and discharge capacitors before servicing could result in death or serious injury. Disconnect all electric power, including remote disconnects and discharge all motor start/run capacitors before servicing. Follow proper lockout/tagout procedures to ensure the power cannot be inadvertently energized. For variable frequency drives or other energy storing components provided by Trane or others, refer to the appropriate manufacturer's literature for allowable waiting periods for discharge of capacitors. Verify with an appropriate voltmeter that all capacitors have discharged.

For additional information regarding the safe discharge of capacitors, see PROD-SVB06-EN*

⚠ WARNING

Personal Protective Equipment (PPE) Required!

Failure to follow proper handling guidelines could result in death or serious injury. Always wear appropriate personal protective equipment in accordance with applicable regulations and/or standards to guard against potential electrical shock and flash hazards.

⚠ WARNING

Live Electrical Components!

Failure to follow all electrical safety precautions when exposed to live electrical components could result in death or serious injury. During installation, testing, servicing and troubleshooting of this product, it may be necessary to work with live electrical components. Have a qualified licensed electrician or other individual who has been properly trained in handling live electrical components perform these tasks.



Note: Graphic labels (shown above) are used for CE application only.

Important:

- Before servicing, disconnect all power sources and allow at least 30 minutes for capacitors to discharge.
- All electrical enclosures—unit or remote—are IP2X.



Electrical Requirements

Trane-Supplied Remote Starter Wiring

Table 13. Standard field power wiring requirements

Power Supply Wiring to Starter Panel	Starter Panel Terminals		
3-Phase Line Voltage	L1, L2, L3, and GROUND ^(a)		
Starter to Motor Power Wiring	Starter	Motor	
Remote Starter to Chiller Motor Junction Box	T1 through T6	T1 through T6	
Power Supply Wiring to Unit-Mounted Control Power Transformer (CPTR Optional)	Control Power Transformer Terminals		
3-Phase Line Voltage ^(b)	6Q1-1,3,5		
Ground	CPTR panel GND		
Starter to Control Panel 120 Vac Control Wiring	Starter Panel Terminals	Unit Control Panel Terminations	
120 Vac Power Supply (from starter to control panel)	2X8-1, 2X8-2 2X8-G (Ground)	1X1-1, 1X1-12 1X1-G (Ground)	
High Pressure Cutout to Starter	2X8-4	1X1-4	
1F1 Circuit Breaker to Starter	2X8-3	1X1-2	
Oil Pump Interlock	2X8-7, 2X8-8	1X1-10, 1X1-21	
LV starter Oil/Refrigerant pump start	2X8-24	1X1-21	
MV starter Oil/Refrigerant pump start	2X8-14	1X1-21	
Oil/Refrigerant pump neutral	2X8-25	1X1-16	
Starter to Oil/Refrigerant Pump Junction Box	Starter Panel Terminals	Oil/Refrigerant Pump Junction Box	
Low Voltage 3-Phase Pump Power	2X8-21, 2X8-22, 2X8-23	4X4-1, 4X4-2, 4X4-3	
Medium Voltage 1-Phase Pump Power	2X8-12, 2X8-13	4X4-1, 4X4-4	
Low Voltage Circuits less than 30 Vac	Starter Panel Terminals	Unit Control Panel Terminations	
Standard Circuits			
Inter Processor Communications (IPC) Remote Mounted ^(c)	2K32-J3-3-4, or 2X1-12 to 13 if present (do not ground shield at starter)	1T2-J53-4 Shield ground at 1X1-G (GND) only.	2 wire with ground Comm link

Notes:

1. All wiring to be in accordance with National Electrical Code and any local codes.
2. Auxiliary equipment must be powered from other sources as the chiller control panel power supplies are sized for the chiller loads only.

(a) Ground lug for a unit-mounted solid state starter or wye-delta starter is sized to accept 14 AWG solid to 8 AWG strand wire. For AWG/MCM equivalents in mm², refer to [Table 12, p. 47](#). If local codes require different lug size, it must be field-supplied and -installed.

(b) Refer to submittal and ship-with wiring schematics for voltage requirements.

(c) Must be separated from 120 Vac and higher wiring.



Customer-Supplied Remote Starter Wiring

Table 14. Standard customer-supplied remote field wiring requirements

Power Supply Wiring to Starter Panel	Starter Panel Terminals		
Starter by others 3-Phase power wiring	See starter by others schematic		
Starter to Motor Power Wiring	Starter	Motor	
Remote Starter to Chiller Motor Junction Box ^(a)	T1 through T6	T1 through T6	
Power Supply Wiring to Unit-Mounted Control Power Transformer (CPTR)	Control Power Transformer Terminals		
3-Phase Line Voltage ^(b)	6Q1-1,3,5		
Ground	CPTR panel GND		
Starter to Control Panel 120 Vac Control Wiring	Starter Panel Terminals	Unit Control Panel Terminations	
Power from control panel 1F1	5X12-3	1X1-2	
Neutral from control panel	5X12-2	1X1-13	
Ground from control panel	5X12-G	1X1-G	
Interlock relay signal	5X12-4	1K23 J10-1	
Start contactor signal	5X12-5	1K23 J8-1	
Oil Pump Interlock	5X12-7, 5X12-8	1X1-10, 1X1-21	
Run contactor signal	5X12-10	1K23 J6-1	
Transition complete	5X12-14	1K23 J12-2	
Solid State Starter Fault ^(c)	5X12-12 5X12-11	1K13 J2-2 1K13 J2-1	
Low Voltage Circuits less than 30 Vac	Starter Panel Terminals	Unit Control Panel Terminations	
Standard Circuits			
	5X12-19	1K23 J7-1	Note: Phasing must be maintained
	5X12-20	1K23 J7-2	
Current Transformers (see Table 15, p. 50) (Required) ^(d)	5X12-21	1K23 J7-3	
	5X12-22	1K23 J7-4	
	5X12-23	1K23 J7-5	
	5X12-24	1K23 J7-6	
Potential Transformers (Required) ^(d)	5X12-25	1K23 J5-1	
	5X12-26	1K23 J5-2	
	5X12-27	1K23 J5-3	
	5X12-28	1K23 J5-4	
	5X12-29	1K23 J5-5	
	5X12-30	1K23 J5-6	

Notes:

1. All wiring to be in accordance with National Electrical Code and any local codes.
2. Refer to ship-with wiring schematics; some terminals may vary based on unit.

(a) For AWG/MCM equivalents in mm², refer to [Table 12, p. 47](#). Wires, lugs, and fuses/breakers are sized based on National Electric Code NEC [NFPA 70] and UL 1995.

(b) Refer to submittal and ship-with wiring schematics for voltage requirements.

(c) Solid State Starter Fault input is used with low-and medium-voltage, customer-supplied solid state starters only.

(d) Must be separated from 120 Vac and higher wiring.



Customer-Supplied Remote Starter Wiring

Current Transformer and Potential Transformer Wire Sizing

For customer-supplied starter-to-chiller unit control panel starter module 1K23; these wires must be separated from 120 Vac or higher wiring.

Table 15. Maximum recommended wire length for secondary CT leads in dual CT system

Wire AWG ^(a)	Maximum Wire Length Secondary CT Leads	
	Meters	Feet
8	415.5	1362.8
10	261.2	856.9
12	164.3	538.9
14	103.3	338.9
16	65.0	213.1
17	51.5	169.1
18	40.9	134.1
20	25.7	84.3

Notes:

1. Wire length is for copper conductors only.
2. Wire length is total one-way distance that the CT can be from the starter module.

(a) For AWG/MCM equivalents in mm², refer to [Table 12, p. 47](#). Wires, lugs, and fuses/breakers are sized based on National Electric Code NEC [NFPA 70] and UL 1995.

Table 16. Maximum recommended total wire length for PTs in a single PT system

Wire AWG ^(a)	Maximum Lead Length	
	Meters	Feet
8	1627	5339
10	1023	3357
12	643	2112
14	404	1328
16	254	835
17	201	662
18	160	525
20	100	330
21	79	262
22	63	207

Notes:

1. Wire length is for copper conductors only.
2. The above length is maximum round trip wire length. The maximum distance the PT can be located from the starter module is half of the listed value.

(a) For AWG/MCM equivalents in mm², refer to [Table 12, p. 47](#). Wires, lugs, and fuses/breakers are sized based on National Electric Code NEC [NFPA 70] and UL 1995.

Table 17. Max recommended total wire length (to and from) for PT leads in a dual PT system

Wire AWG ^(a)	Max Wire Length Primary		Max Wire Length Secondary	
	Meters	Feet	Meters	Feet
8	933	3061	217	711
10	586	1924	136	447
12	369	1211	85	281
14	232	761	53	177
16	145	478	33	111
17	115	379	26	88
18	91	301	21	70
20	57	189	13	44
21	45	150	10	34
22	36	119	8	27

Notes:

1. Wire length is for copper conductors only.
2. The above length is maximum round trip wire length. The maximum distance the PT can be located from the starter module is half of the listed value.

(a) For AWG/MCM equivalents in mm², refer to [Table 12, p. 47](#). Wires, lugs, and fuses/breakers are sized based on National Electric Code NEC [NFPA 70] and UL 1995.

Power Supply Wiring

⚠ WARNING

Proper Field Wiring and Grounding Required!

Failure to follow code could result in death or serious injury. All field wiring **MUST** be performed by qualified personnel. Improperly installed and grounded field wiring poses **FIRE** and **ELECTROCUTION** hazards. To avoid these hazards, you **MUST** follow requirements for field wiring installation and grounding as described in **NEC** and your local/state/national electrical codes.



Note: Graphic labels (shown above) are used for CE application only.

Important:

- Before servicing, disconnect all power sources and allow at least 30 minutes for capacitors to discharge.
- All electrical enclosures—unit or remote—are IP2X.

Three-Phase Power

Review and follow the guidelines below to properly install and connect the power supply wiring to the starter panel:

- Verify that the starter nameplate ratings are compatible with the power supply characteristics and with the electrical data on the unit nameplate.

NOTICE:

Starter Component Damage!

Failure to remove debris from inside the starter panel could result in an electrical short and could cause serious starter component damage.

NOTICE:

Use Copper Conductors Only!

Failure to use copper conductors could result in equipment damage as unit terminals are not designed to accept other types of conductors.

- Do *not* modify or cut enclosure to provide electrical access. Removable panels have been provided, and any modification should be done away from the enclosure. If the starter enclosure must be cut to provide electrical access, exercise care to prevent debris from falling inside the enclosure.
- Use copper conductors to connect the three-phase power supply to the remote- or unit-mounted starter panel.
- Flexible conduit connections are recommended to enhance serviceability and minimize vibration transmission.
- Size the power supply wiring in accordance with NEC and local guidelines, using the RLA value stamped on the chiller nameplate and transformer load on L1 and L2.
- Confirm that wire size is compatible with lug size stated in unit submittal.
- Make sure that the incoming power wiring is properly phased; each power supply conduit run to the starter must carry the correct number of conductors to ensure equal phase representation.

Note: Connect L1, L2, and L3 (shown below) per starter diagram provided with chiller.

Power Supply Wiring

Unit-Mounted Starters

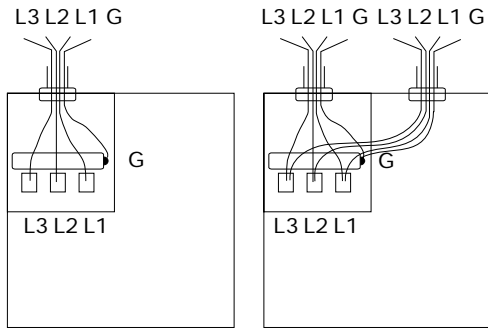

Remote-Mounted Starters

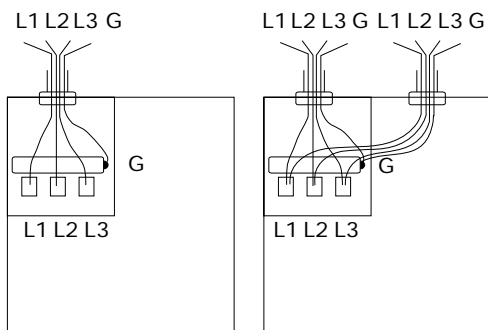

- When installing the power supply conduit, ensure that the position of the conduit does not interfere with the serviceability of any of the unit components, or with structural members and equipment. Ensure that the conduit is long enough to simplify any servicing that may be necessary in the future (e.g., starter).
- Electrical wire torque specifications—follow starter manufacturer's torque specifications.

Circuit Breakers and Fused Disconnects

Any field supplied circuit breaker or fused disconnect installed in power supplied to the chiller must be sized in compliance with NEC or local guidelines.

CE for Control Power Transformer (CPTR) Option

Important: For the CPTR (Control Power Transformer) option, chiller mounted/UPS power, the customer needs to ensure that the supply is NOT taken from public low voltage supplies, and that a dedicated clean source of private power supply is used for chiller mounted CPTR option when a CE chiller is selected. This also includes when CPTR option is standard such as in customer-supplied starters and remote-mounted medium voltage AFDs.

All customer wiring, including power wiring to starters/drives/CPTR Option/UPS shore power, needs to be separated: 24–27 Vdc, 110–120 Vac, and 380–600 Vac each need to be in separate conduit runs.

For 110/120 V customer wiring, including main power supply to CPTR option, it is required that the customer provides some sort of surge protection ahead of it, and all customer wiring needs to be run in conduit. Any ethernet cables being used by customer to interface with the Trane chiller must be shielded ethernet cabling.

The customer is required to provide an overcurrent device upstream of the CPTR option in accordance with IEC standards and/or any applicable local and national codes.

The customer is required to follow all local, national, and/or IEC codes for installation.

Service personnel must use proper PPE for servicing and should also use proper lockout/tagout procedures during servicing. The customer should also disconnect the main supply disconnecting device upstream of the starter or drive first before performing any service on any part of the chiller, including the CPTR option, related controls, and oil pump motor circuits. In addition, service personnel should first disconnect the supply disconnecting device upstream of the CPTR option before performing any service on the CPTR option or its related circuits. Lock the CPTR option enclosure panel disconnect handle before servicing to prevent accidental pulling of the disconnect handle.

CE for Starter or Drive

Important:

- All Trane-supplied remote starters and drives used in conjunction with CVHH or CDHH Trane chillers will be CE-compliant per EU directives and IEC standards to which the CVHH and CDHH chillers also comply. All Trane-supplied remote starters and drives must be used with CVHH or CDHH Trane chillers to ensure CE compliance.
- For remote starters and drives: Basic details are provided on remote starter/drive nameplate. Please refer to the chiller unit nameplate located on the chiller mounted control panel for details on wire sizing (minimum current ampacity) and overcurrent protection sizing upstream of the unit (maximum overcurrent protection).
- Always refer to as-built schematic wiring diagrams and the chiller Installation, Operation, and Maintenance manual located inside the chiller mounted control panel (regardless of unit or remote-mounted starter or drive) for details on wiring, safety, installation, and warnings.
- Refer to drive-specific Installation, Operation, and Maintenance manuals for drive and option installation specifics for unit- and remote-mounted adaptive frequency drives.
- Customers are responsible for all field wiring with respect to EMC and EMI interference. Customers are

responsible to mitigate the risks associated with EMC and EMI interference that can occur as a result of customer-provided field wiring as dictated by international, national, and local codes. This also implies that for remote-mounted starters and drives, customers are responsible for the entire field wiring into the starter/drive as well as between the starter/drive and the chiller/compressor terminals with respect to EMC and EMI interference. It also implies that customers are responsible for incoming power wiring to both the starter/drive and CPTR option enclosure unit-mounted panel with respect to EMC and EMI interference.

All customer wiring, including power wiring to starters/drives/CPTR Option/UPS shore power, needs to be separated: 24–27 Vdc, 110–120 Vac, and 380–600 Vac each need to be in separate conduit runs.

For 110/120V customer wiring, including power supply to CPTR option, it is required that the customer provides some sort of surge protection and all customer wiring needs to be run in conduit.

For remote starters interfacing with the Trane chiller, all wiring needs to be run in conduit. Any ethernet cables being used by customer to interface with the Trane chiller must be shielded ethernet cabling.

The customer is required to provide an overcurrent protective device upstream of all starters and drives in accordance with IEC standards and/or any applicable local and national codes.

Service personnel must use proper PPE for servicing and should also use proper lockout/tagout procedures during servicing: lock the starter disconnect handle before servicing to prevent accidental pulling of disconnect handle at the starter panel. In addition, service personnel should first disconnect the main supply disconnecting device upstream of the starter or drive before performing any service on any part of the chiller.



Note: Graphic labels (shown above) are used for CE application only.

Important:

- Before servicing, disconnect all power sources and allow at least 30 minutes for capacitors to discharge.
- All electrical enclosures—unit or remote—are IP2X.

For CE units, the convenience outlet in the control panel requires a suitable adaptor to meet the needs of customers with different plug requirements.

⚠ WARNING

Lockout/Tagout Before Removing Touch-Safe Covers!

Failure to follow instructions regarding touch-safe covers could result in death or serious injury. Touch-safe covers inside panels are there for protection and may be removed if necessary for service only and only after disconnection of main power supply. Before removing any touch-safe cover, ensure that there is no line power first. Removal of touch-safe covers would be at the customer/service personnel's own risk. After any service is completed, if the touch-safe covers have been removed, the touch-safe covers need to be put back in to ensure safety and protection.



Power Supply Wiring

Control Power Transformer (CPTR) Option

The CPTR option provides a means to isolate the incoming line voltage required for the chiller control circuits and the oil/refrigerant pump from the compressor incoming line voltage. The CPTR option provides a solution for customers that cannot afford to lose communication with the chiller or extended restart times due to lost incoming power.

The CPTR option will benefit:

- UPS customers
- Customers requiring fast restarts
- Customers who need controls sourced from a clean dedicated source
- Customers with building automation/communication systems who want to maintain chiller status reporting during power loss
- Chillers with remote-mounted medium-voltage AFDs or customer-supplied starters

NOTICE:

CPTR Option Enclosure Panel Damage!

Failure to remove debris from inside the CPTR option enclosure panel could result in an electrical short and could cause serious component damage.

The standard unit-mounted CPTR option shall have an enclosure with a disconnect and will require customer-supplied power.

CVHH and CDHH chillers have a low-voltage CPTR option and a medium-voltage CPTR option.

The CPTR option involves a single phase 4kVA transformer(s) and the oil pump motor circuit to be located together in an enclosure that is unit-mounted. There is 3-phase line power between 380–600 Vac feeding this enclosure. Wherever the 4kVA transformer is located, the oil pump motor circuit will be located along with it.

With the CPTR option, the control power transformer(s) and oil pump motor circuit are NOT inside of the starter.

For the low-voltage CPTR option, the single phase 4kVA transformer feeds the 120 V control power to all of the controls. The three-phase line power feeds a motor starter and overload oil pump motor circuit which feeds the three-phase oil pump motor.

For the medium-voltage CPTR option, there are two single-phase 4-kVA transformers: one of the 4 kVA transformers feeds the 120 V control power to all of the controls. The second transformer feeds a combination motor controller oil pump motor circuit which then feeds a single-phase oil pump motor.

Note: Refer to the unit nameplate for maximum overcurrent protection and minimum current ampacity values for connecting to the CPTR option enclosure.

Service personnel are required to ensure that the incoming power supply voltage provided by the customer to the CPTR option enclosure unit-mounted panel is as per submittal and nameplate.

Power Factor Correction Capacitors (Optional)

Power factor correction capacitors (PFCCs) are designed to provide power factor correction for the compressor motor. PFCCs are available as an option for unit-mounted starters and remote mounted starters.

Notes:

- *Verify PFCC voltage rating is greater than or equal to the compressor voltage rating stamped on the unit nameplate.*
- *Refer to the wiring diagrams that shipped with the unit for specific PFCC wiring information.*

NOTICE:

Motor Damage!

Failure to wire PFCCs into the starter correctly could cause misapplication of these capacitors and result in a loss of motor overload protection and subsequently cause motor damage.

PFCCs must be wired one of two ways as shown as explained in the following (Option 1 and Option 2).



Note: Graphic labels (shown above) are used for CE application only.

Important:

- Before servicing, disconnect all power sources and allow at least 30 minutes for capacitors to discharge.
- All electrical enclosures—unit or remote—are IP2X.

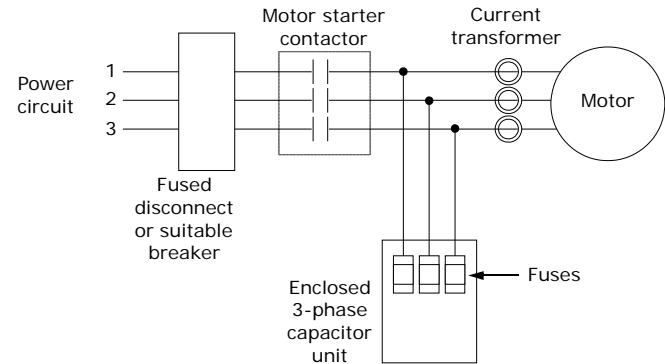

Option 1—PFCCs installed downstream of starter contactor, upstream of current transformers.

⚠ WARNING

Hazardous Voltage w/Capacitors!

Failure to disconnect power and discharge capacitors before servicing could result in death or serious injury. Disconnect all electric power, including remote disconnects and discharge all motor start/run capacitors before servicing. Follow proper lockout/tagout procedures to ensure the power cannot be inadvertently energized. For variable frequency drives or other energy storing components provided by Trane or others, refer to the appropriate manufacturer's literature for allowable waiting periods for discharge of capacitors. Verify with an appropriate voltmeter that all capacitors have discharged.

For additional information regarding the safe discharge of capacitors, see PROD-SVB06-EN*



Note: Graphic labels (shown above) are used for CE application only.

Important:

- Before servicing, disconnect all power sources and allow at least 30 minutes for capacitors to discharge.
- All electrical enclosures—unit or remote—are IP2X.

Simultaneously disconnect capacitors and load from line power. If the capacitors are not switched offline when the load is disconnected, they continue to add capacitance to

the electrical distribution system. A *leading* power factor—too much capacitance—may eventually develop. This overprotection causes poor voltage regulation (i.e., voltage is high when the circuit is unloaded, then drops as loads are added).

Option 2—PFCC wires routed through current transformers.

Size motor overload protection to account for capacitor-supplied current. Overloads are typically set to measure the total current drawn by the motor. When PFCCs are used, they become the source of part of that current. If the current they provide is not registered by the overload protectors, potentially damaging amperage can reach the motor. The simplest way to ensure that the overloads detect all current supplied to the motor is to position the PFCCs upstream of the current transformers as shown in the preceding figure. If the capacitor connection points are downstream of the current transformers, route the PFCC leads through the current transformers as shown in the following figure. This ensures that the overloads register both line and capacitor-supplied current.

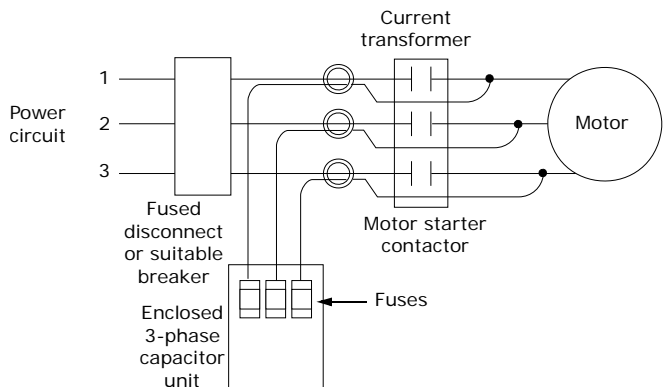

Interconnecting Wiring

Typical equipment room conduit layouts with and without unit-mounted starters are shown in [Figure 30](#) and [Figure 31](#).

Important: *The interconnecting wiring between the starter panel, compressor, and control panel is factory-installed with unit-mounted starters. However, when a remote-mounted starter is used, the interconnecting wiring must be field-installed.*

Note: Refer to starter submittal drawing for location of incoming wiring to the starter.

Figure 30. Typical equipment room layout for units with unit-mounted starters

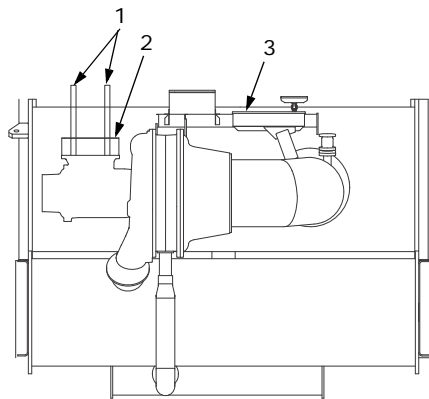

1. Line side power conduits
2. Unit-mounted starter
3. Unit control panel

Figure 31. Typical equipment room layout for units with remote-mounted starters

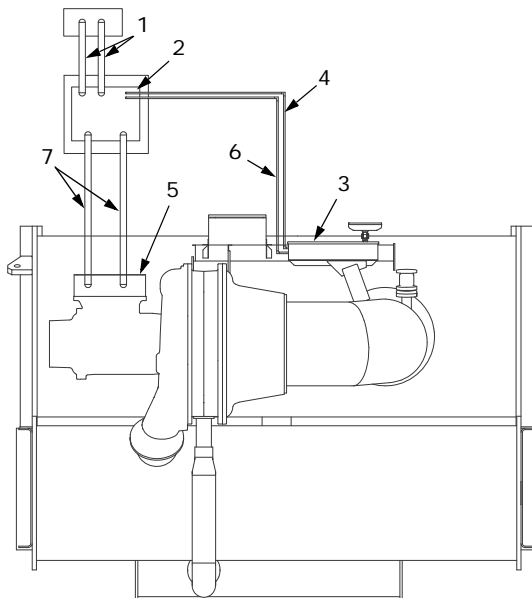

Figure 31. Typical equipment room layout for units with remote-mounted starters

1. Line side power conduits
2. Remote-mounted starter
3. Unit control panel
4. IPC Circuit conduit less than 30V (and CT/PT wiring for starters by others)

Note: Must enter the low voltage Class 2 portion of the unit control panel (304.8 m [1000 feet] max).

5. Motor terminal box
6. 115 V Control conduit

Note: Must enter the higher than 30 Vdc Class 1 portion of the unit control panel.

7. Lead power wiring

Notes:

- Refer to the unit field connection diagram for approximate unit control panel knock out locations.
- To prevent damage to the unit control panel components, do not route control conduit into the top of the box.

Starter to Motor Wiring (Remote-Mounted Starters Only)

Ground Wire Terminal Lugs

Ground wire lugs are provided in the motor terminal box and in the starter panel.

Terminal Clamps

NOTICE:

Use Copper Conductors Only!

Failure to use copper conductors could result in equipment damage as unit terminals are not designed to accept other types of conductors.



Note: Graphic labels (shown above) are used for CE application only.

Important:

- Before servicing, disconnect all power sources and allow at least 30 minutes for capacitors to discharge.
- All electrical enclosures—unit or remote—are IP2X.

Terminal clamps are supplied with the motor terminals to accommodate either bus bars or standard motor terminal wire lugs. Terminal clamps provide additional surface area to minimize the possibility of improper electrical connections.

Wire Terminal Lugs

Wire terminal lugs must be field supplied.

- Use field-provided, crimp-type wire terminal lugs properly sized for the application.

Note: Wire size ranges for the starter line and load-side lugs are listed on the starter submittal drawings supplied by the starter manufacturer or Trane. Carefully review the submitted wire lug sizes for compatibility with the conductor sizes specified by the electrical engineer or contractor.

- On 600 V and below, a terminal clamp with a 9.525-mm (3/8-in.) bolt is provided on each motor terminal stud; use the factory-supplied Belleville washers on the wire lug connections. Figure 32 illustrates the junction between a motor terminal stud and terminal lug.

Figure 32. Terminal stud, clamp, and lug assembly (600 V and below)

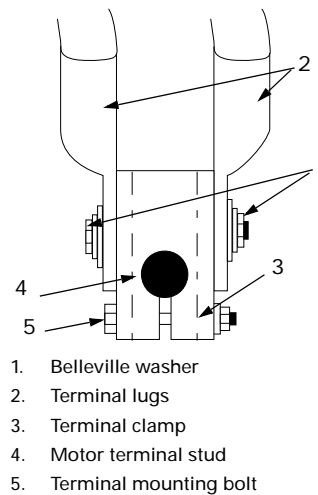

1. Belleville washer
2. Terminal lugs
3. Terminal clamp
4. Motor terminal stud
5. Terminal mounting bolt

- Torque for this assembly is 32.5 N·m (24 ft·lb).
- Install but do *not* connect the power leads between the starter and compressor motor. (These connections will be completed under supervision of a qualified Trane service engineer after the pre-start inspection.)

NOTICE:

Component Damage!

Failure to ensure the power supply wiring and output to motor wiring are connected to the proper terminals, could cause catastrophic failure of the starter and/or motor.

Bus Bars

Bus bars and extra nuts are available as a Trane option.

Install the bus bars between the motor terminals when using a starter that is:

- a low-voltage AFD
- across-the-line
- primary reactor/resistor
- auto transformer
- customer-supplied

Connect T1 to T6, T2 to T4, and T3 to T5.

Note: Bus bars are not needed in medium-voltage or high-voltage applications since only 3 terminals are used in the motor and starter.

Starter to Control Panel Wiring

The unit submittal includes the field wiring connection diagram and the starter-to-control-panel connection diagram (showing the electrical connections required between the remote-mounted starter and the control panel).

Note: Install separate conduit into the low voltage (30 volts) section of the control panel.

When sizing and installing the electrical conductors for these circuits, follow the guidelines listed. Use 14 AWG for 120V control circuits unless otherwise specified. For AWG/MCM equivalents in mm², refer to [Table 12, p. 47](#).

NOTICE:

Component Damage!

Remove all debris from inside the starter panel. Failure to do so could result in an electrical short and could cause serious starter component damage.

Important: Maintain at least 16 cm (6 in.) between low-voltage (<30V) and high voltage circuits. Failure to do so could result in electrical noise that may distort the signals carried by the low voltage wiring, including the IPC wiring.

To wire the starter to the control panel, follow the guidelines below:

- If the starter enclosure must be cut to provide electrical access, exercise care to prevent debris from falling inside the enclosure. Do *not* cut AFD enclosure.
- Use only shielded, twisted-pair wiring for the Interprocessor Communication (IPC) circuit between the starter and the control panel on remote mounted starters.

Note: Recommended wire is Beldon Type 8760, 18 AWG for runs up to 304.8 m (1000 ft). For AWG/MCM equivalents in mm², refer to [Table 12, p. 47](#). The polarity of the IPC wiring is critical for proper operation.

- Separate low-voltage (less than 30V; refer to [Table 13, p. 48](#)) wiring from the 115V wiring by running each in its own conduit.
- When routing the IPC circuit out of the starter enclosure, ensure that it is at least 16 cm (6 in.) from all wires carrying a higher voltage.

⚠ WARNING

Proper Field Wiring and Grounding Required!

Failure to follow code could result in death or serious injury. All field wiring **MUST** be performed by qualified personnel. Improperly installed and grounded field wiring poses **FIRE** and **ELECTROCUTION** hazards. To avoid these hazards, you **MUST** follow requirements for field wiring installation and grounding as described in **NEC** and your local/state/national electrical codes.



Note: Graphic labels (shown above) are used for CE application only.

Important:

- Before servicing, disconnect all power sources and allow at least 30 minutes for capacitors to discharge.
- All electrical enclosures—unit or remote—are IP2X.
- The IPC wiring shield should be grounded on one end only at control panel end. The other end should be un-terminated and taped back on the cable sheath to prevent any contact between shield and ground.
- Oil Pump Interlock: All starters must provide an interlock (normally open) contact with the chiller oil pump connected to the control panel at terminals 1X1-10 and 1X1-21 (14 AWG; for AWG/MCM equivalents in mm², refer to [Table 12, p. 47](#).) The purpose of this interlock is to maintain the oil pump signal in the event that a starter failure, such as welded



Power Supply Wiring

contacts, keeps the chiller motor running after the controller interrupts the run signal.

Medium Voltage Installation

⚠ WARNING

Hazardous Voltage!

Failure to disconnect power before servicing could result in death or serious injury. Disconnect all electric power, including remote disconnects before servicing. Follow proper lockout/tagout procedures to ensure the power can not be inadvertently energized.



Note: Graphic labels (shown above) are used for CE application only.

Important:

- Before servicing, disconnect all power sources and allow at least 30 minutes for capacitors to discharge.
- All electrical enclosures—unit or remote—are IP2X.

All electrical circuits shall be treated as energized until all lockout-tagout procedures are in place and the circuit has been tested to verify that it is de-energized. The medium voltage motor terminal box cover must not be removed if power is present, or if there is a possibility that power may be present. Working on energized medium voltage circuits is not an approved practice for normal HVAC maintenance or service.

Medium Voltage Motor

The motor is suitable for remote mounted across-the-line (including circuit breaker starting), primary reactor,

autotransformer, or solid-state starting. Refer to the unit nameplate for motor data including RLA, LRA, etc.

In all cases of non-Trane supplied starters, the Trane Engineering Specification for UC800 Starter By Others (available through your local Trane office) must be followed in order to ensure proper function and protection of the chiller. A disconnecting means and short-circuit protection must be installed ahead of the starter, unless they are included as part of the starter.

Note: Trane assumes no responsibility for the design, documentation, construction, compatibility, installation, start-up, or long term support of starters provided by others.

Motor Terminal Box

A large steel motor terminal box is provided to allow for the field connection of the motor power supply wire to the motor. There are three sizes available depending on voltage and motor frame size.

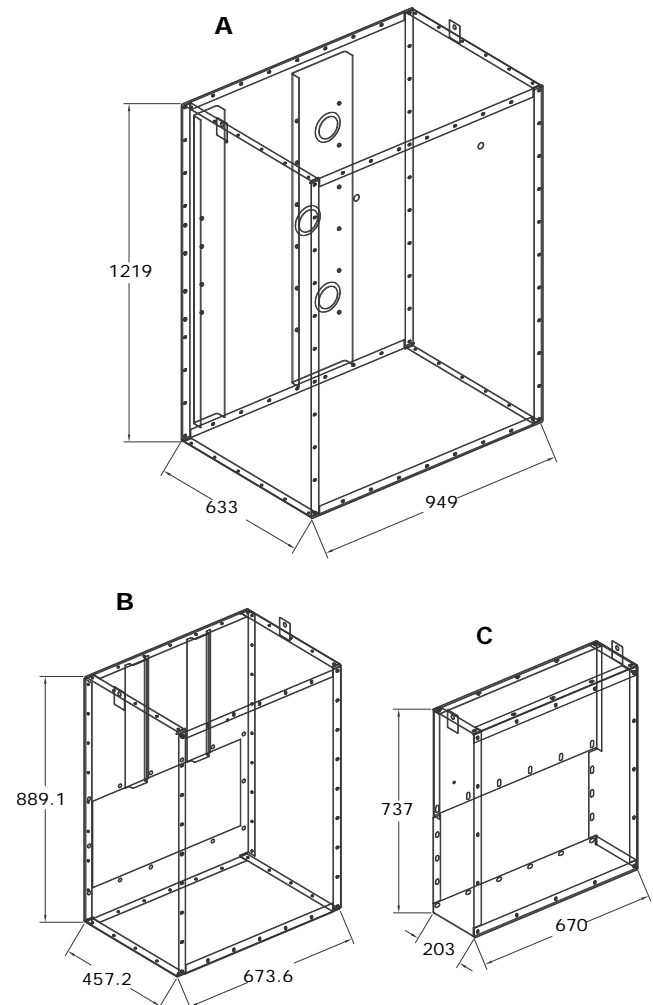

Medium Voltage Installation

	Box Weight (kg)	Volt Range
A	256 ^(a)	6000–13.8kV Frame 6800, 6800L
B	117.3	2300–13.8kV Frame 440E, 5000, 5800, 580L
C	58.5	380–600 Vac Frame 440E, 5000

Note: Lifting holes are 14.3 mm.

(a) Motor terminal box cover-only weight is 24.9 kg (55 lb).

Note: If the box is removed for installation purposes, the motor terminals MUST be protected against impact or stress damage. Field fabrication of a cover or guard is required.

- The motor terminal box is large enough to accommodate the use of stress cones.
- If conduit is applied, a flexible connection of the conduit to the box should be made to allow for unit serviceability and for vibration isolation. The cable should be supported or protected against abrasion and wear on any edges or surfaces. Cable or conduit openings can be cut at any location in the box sides, top, or bottom for cable entry. Always ensure that debris does not remain in the box after cutting cable entry holes.

Motor Supply Wiring

⚠ WARNING

Proper Field Wiring and Grounding Required!

Failure to follow code could result in death or serious injury. All field wiring **MUST** be performed by qualified personnel. Improperly installed and grounded field wiring poses **FIRE** and **ELECTROCUTION** hazards. To avoid these hazards, you **MUST** follow requirements for field wiring installation and grounding as described in **NEC** and your local/state/national electrical codes.



Note: Graphic labels (shown above) are used for CE application only.

Important:

- Before servicing, disconnect all power sources and allow at least 30 minutes for capacitors to discharge.
- All electrical enclosures—unit or remote—are IP2X.

Motor circuit wire sizing by the installer must be made in accordance with the National Electric Code or any other applicable codes.

Three terminals are provided on the chiller for the connection of power to the motor from the starter. Power leads to motors must be in multiples of three, with equal phase representation in all conduits or wire trays. To limit the effects of corona or ionization with cables carrying more than 2000V, Trane requires that the power cable have a metallic shield, unless the cable is specifically listed or

approved for non-shielded use. If the cable is shielded, the shielding must be grounded at one end (grounding is typically done at the starter or supply end).

Care must be taken while routing the incoming cables to ensure that cable loads or tensions are not applied to the terminal or premature terminal failure could result.

Motor Terminals

Field-provided, ring-type lugs, with no sharp edges or corners, must be used by a qualified installer to connect the power wiring to the motor terminals. Follow all instructions provided with the field-provided lugs to ensure proper connections.

Important: The use of stress cones is highly recommended to reduce and control longitudinal and radial electrical stresses at the cable ends.

Prior to assembly the terminal stud, nuts, and lug should be inspected and cleaned to ensure they are not damaged or contaminated. When attaching starter leads to 2.3–6.6 kV motor terminals, the M14x2 brass jam nuts should be tightened to a maximum torque of 32.5–40.7 N·m (24–30 ft·lb). Always use a second wrench to backup the assembly and prevent applying excessive torque to the terminal shaft.

Note: 6.0kV and 6.6kV motors on 6800 or 6800L frames (see compressor model number for motor frame) use the same motor terminals as the 10kV–13.8kV motors.

The motor terminal on a 10–13.8kV motor has a copper shaft that is threaded M14 x 2–6 G. Brass nuts are provided on the motor terminals to retain the lugs, and the final connection should be tightened to 32.5–40.7 N·m (24–30 ft·lb).

chiller with the motor terminal box cover removed or with any loose or missing cover bolts.

NOTICE:

Motor Terminal Damage!

Applying torque to the motor terminal when tightening lugs could cause equipment or property-only damage. Always use a second wrench to back-up the assembly and prevent the application of torque to the terminal shaft.

Before beginning wiring and torquing, ensure proper motor terminal care and do not apply any excess stress.

Ground Wire Terminal Lug

A ground wire lug is provided in the motor terminal box to allow the field connection of an earth ground. The lug will accept a field supplied ground wire of #8 to #2 AWG. For AWG/MCM equivalents in mm², refer to [Table 12, p. 47](#). After completing the field connection of wiring, inspect and clean the motor terminals and motor housing, and remove any debris before reinstalling the motor terminal box cover. The cover must be re-installed onto the motor terminal box and all bolts installed. Do not operate the

CE for Medium Voltage Starter

⚠ WARNING

Hazardous Voltage w/Capacitors!

Failure to disconnect power and discharge capacitors before servicing could result in death or serious injury. Disconnect all electric power, including remote disconnects and discharge all motor start/run capacitors before servicing. Follow proper lockout/tagout procedures to ensure the power cannot be inadvertently energized. Verify with an appropriate voltmeter that all capacitors have discharged.

For additional information regarding the safe discharge of capacitors, see PROD-SVB06A-EN



- Mounting a motor starter on or over a combustible surface could result in a fire. To minimize the risk of possible fires, a floor plate of at least 1.43 mm (0.056 in.) thick galvanized or 1.6 mm (0.63 in.) thick uncoated steel extending at least 150 mm (5.9 in.) beyond the equipment on all four sides must be used.



Note: Graphic labels (shown above) are used for CE application only.

Important:

- Before servicing, disconnect all power sources and allow at least 10 minutes for capacitors to discharge.
- All electrical enclosures—unit or remote—are IP2X.
- Customers are responsible for all field wiring in compliance with local, national, and/or international codes.
- Any fuses inside the medium voltage starter enclosure may be energized.
- PFCC fuses must be installed before energizing medium voltage starter.
- Do NOT modify or disassemble the medium voltage starter.
- Use only factory-authorized replacement parts.
- Do NOT install or energize the medium voltage starter if it has been damaged.
- Contactor must be bolted in place after installation; maximum torque is 19.0 N·m (14 ft·lb).



System Control Circuit Wiring (Field Wiring)

Table 18. Unit control panel wiring 120 Vac

Standard Control Circuits: Unit Control Panel Control Wiring (120 Vac)	Unit Control Terminations	Input or Output Type	Contacts
Chilled Water Flow Proving Input ^(a)	1X1-5 to 1K16-J3-2	Binary Input	Normally Open, closure with flow
Condenser Water Flow Proving Input ^(b)	1X1-6 to 1K16-J2-2	Binary Input	Normally Open, closure with flow
Chilled Water Pump Relay Output	1K15-J2-4 to 6	Binary Output	Normally Open
Condenser Water Pump Relay Output	1K15-J2-1 to 3	Binary Output	Normally Open
Optional Control Circuits (120 Vac)	Note: Defaults are factory programmed, alternates can be selected at start-up using the service tool.		
Alarm Relay MAR (Non-Latching) Output	1K19-J2-1 to 3	Binary Output	Normally Open
Limit Warning Relay Output	1K19-J2-4 to 6	Binary Output	Normally Open
Alarm Relay MMR (Latching) Output	1K19-J2-7 to 9	Binary Output	Normally Open
Compressor Running Relay Output	1K19-J2-10 to 12	Binary Output	Normally Open
Maximum Capacity Relay Output	1K20-J2-1 to 3	Binary Output	Normally Open
Head Relief Request Relay Output	1K20-J2-4 to 6	Binary Output	Normally Open
Purge Alarm Relay Output	1K20-J2-7 to 9	Binary Output	Normally Open
Ice Making Relay Output	1K15-J2-10 to 12	Binary Output	Normally Open
Free Cooling Relay Output	1K21-J2-4 to 6	Binary Output	Normally Open
Standard Low Voltage Circuits (less than 30 Vac)^(c)	Unit Control Panel Terminations	Input or Output Type	Contacts
External Auto Stop Input	1K2-J2-1 to 2	Binary Input	Closure required for normal operation
Emergency Stop Input	1K2-J2-3 to 4	Binary Input	Closure required for normal operation
Optional Low Voltage Circuits			
External Base Loading Enable Input	1K8-J2-1 to 2	Binary Input	Normally Open
External Hot Water Control Enable Input	1K8-J2-3 to 4	Binary Input	Normally Open
External Ice Machine Control Enable Input	1K9-J2-1 to 2	Binary Input	Normally Open
External Free Cooling Input Enable Input	1K10-J2-1 to 2	Binary Input	Normally Open
% RLA Compressor Output	1K5-J2-1 to 3	Analog Output	2–10 Vdc
External Condenser Pressure Output	1K5-J2-4 to 6	Analog Output	2–10 Vdc
Evaporator/Condenser Differential Pressure Output	1K5-J2-4 to 6	Analog Output	2–10 Vdc
Condenser Head Pressure Control	1K5-J2-4 to 6	Analog Output	2–10 Vdc
External Current Limit Setpoint Input	1K6-J2-2 to 3	Analog Input	2–10 Vdc, or 4–20 mA
External Chilled Water Setpoint Input	1K6-J2-5 to 6	Analog Input	2–10 Vdc, or 4–20 mA
External Base Loading Setpoint Input	1K7-J2-2 to 3	Analog Input	2–10 Vdc, or 4–20 mA
Generic Refrigerant Monitor input	1K7-J2-5 to 6	Analog Input	2–10 Vdc, or 4–20 mA
Outdoor Air Temperature sensor	IPC bus Connection and sensor	Communication and sensor	
Tracer Comm 4 Interface	1K3-J2-1(+) to 2(-) 1K3-J2-3(+) to 4(-)	Communication to Tracer	(as ordered, see sales order)
BACnet or MODBUS	1K1, 5(+) to 6(-)	Communication to BACnet or MODBUS	(as ordered, see sales order)
LonTalk Comm 5 interface	1K4-J2-1(+) to 2(-) 1K4-J2-3(+) to 4(-) Left Panel	Communication to LonTalk	(as ordered, see sales order)

Note: All wiring to be in accordance with National Electrical Codes and any local codes

- (a) If the Chilled Water Flow Proving Input is a factory-installed ifm effector flow-sensing device, the secondary field device (recommended with 3.3°C [38°F] and lower leaving chilled water temperatures) for proof of flow connects from 1X1-5 to 1K26-4 (binary input; normally open, closure with flow). Remove factory jumper when used.
- (b) If the Condenser Water Flow Proving Input is a factory-installed ifm effector flow-sensing device, the secondary (optional) field device for proof of flow connects from 1X1-6 to 1K27-4 (binary input; normally open, closure with flow). Remove factory jumper when used.

(c) Standard low-voltage circuits (less than 30 Vac) must be separated from 120 Vac or higher wiring.

Water Pump Interlock Circuits and Flow Switch Input

⚠ WARNING

Hazardous Voltage!

Failure to disconnect power before servicing could result in death or serious injury. Disconnect all electric power, including remote disconnects before servicing. Follow proper lockout/tagout procedures to ensure the power can not be inadvertently energized.



Note: Graphic labels (shown above) are used for CE application only.

Important:

- Before servicing, disconnect all power sources and allow at least 30 minutes for capacitors to discharge.
- All electrical enclosures—unit or remote—are IP2X.

Note: The circuits for the chilled water proof of flow and the condenser water proof of flow do NOT require external power. Refer to the wiring diagrams that shipped with the chiller.

Chilled water pump

1. Wire the evaporator water pump contactor (5K42) to a separate 120 volt single phase power supply with 14 AWG, 600 volt copper wire. For AWG/MCM equivalents in mm², refer to [Table 12, p. 47](#).

2. Connect circuit to 1K15-J2-6.
3. Use 1K15-J2-4 120 Vac output to allow the control panel to control the evaporator water pump, or wire the 5K1 contactor to operate remotely and independently of the control panel.

Chilled water proof of flow

When this circuit is installed properly and the evaporator pump is running and providing the required minimum flow, this circuit will prove the evaporator water flow for the chiller controls. Proof of evaporator water flow is required before the start sequence will be allowed to proceed and a loss of evaporator water flow during chiller operation will result in a chiller shut-down.

Refer to as-built schematics on the inside of the control panel for field wiring. This is a dry binary input; normally-open, closure for flow. Apply no external power.

1. With factory-installed ifm efector flow-sensing devices, a field-provided secondary flow-sensing device is recommended with applications having 3.3°C (38°F) and below leaving evaporator water temperatures. When a secondary flow-sensing device is used, remove the factory jumper and install its contacts between 1X1-5 to 1K26-4; this places the secondary flow sensing device in series with the ifm efector.
2. For field-provided primary proof of flow devices, connect the primary proof of flow device between terminals 1X1-5 to 1K16-J3-2. A secondary field device is recommended with applications having 3.3°C (38°F) and below leaving evaporator water temperatures, and must be field-wired in series with the primary proof of flow device.

Condenser water pump

1. Wire the condenser water pump contactor (5K43) to a separate 120-volt, single phase power supply with 14 AWG, 600-volt copper wire. For AWG/MCM equivalents in mm², refer to [Table 12, p. 47](#).
2. Connect circuit to control panel terminals 1K15-J2-3.
3. Use 1K15-J2-1 120 Vac output to allow the control panel to control the condenser pump.

Condenser water proof of flow

When this circuit is installed properly and the condenser pump is running and providing the required minimum condenser water flow, this circuit will prove the condenser water flow for the chiller controls. Proof of condenser water flow is also required for the start sequence will be allowed to proceed and a loss of condenser water flow during chiller operation will result in a chiller shut-down.

Refer to as-built schematics on the inside of the control panel for field wiring. This is a dry binary input; normally-open, closure for flow. Apply no external power.

1. With factory-installed ifm efector flow-sensing devices, a secondary field-provided flow-sensing device is optional. When a secondary flow-sensing device is used, remove the factory jumper, and install its contacts between 1X1-5 to 1K27-4; this places the secondary flow sensing device in series with the ifm efector.
2. For field-provided primary proof of flow devices, connect the primary proof of flow device between terminals 1X1-6 to 1K16-J2-2. The secondary field provided flow sensing device is optional; however, when it is present, it must be field-wired in series with the primary proof of flow device.

Temperature Sensor Circuits

All temperature sensors are factory installed except the optional outdoor air temperature sensor (refer to [Figure 33, p. 67](#) for sensor locations). This sensor is required for the outdoor air temperature type of chilled water reset. Use the following guidelines to locate and mount the outdoor air temperature sensor. Mount the sensor probe where needed, however, mount the sensor module in the control panel.

Figure 33. CVHH sensor locations

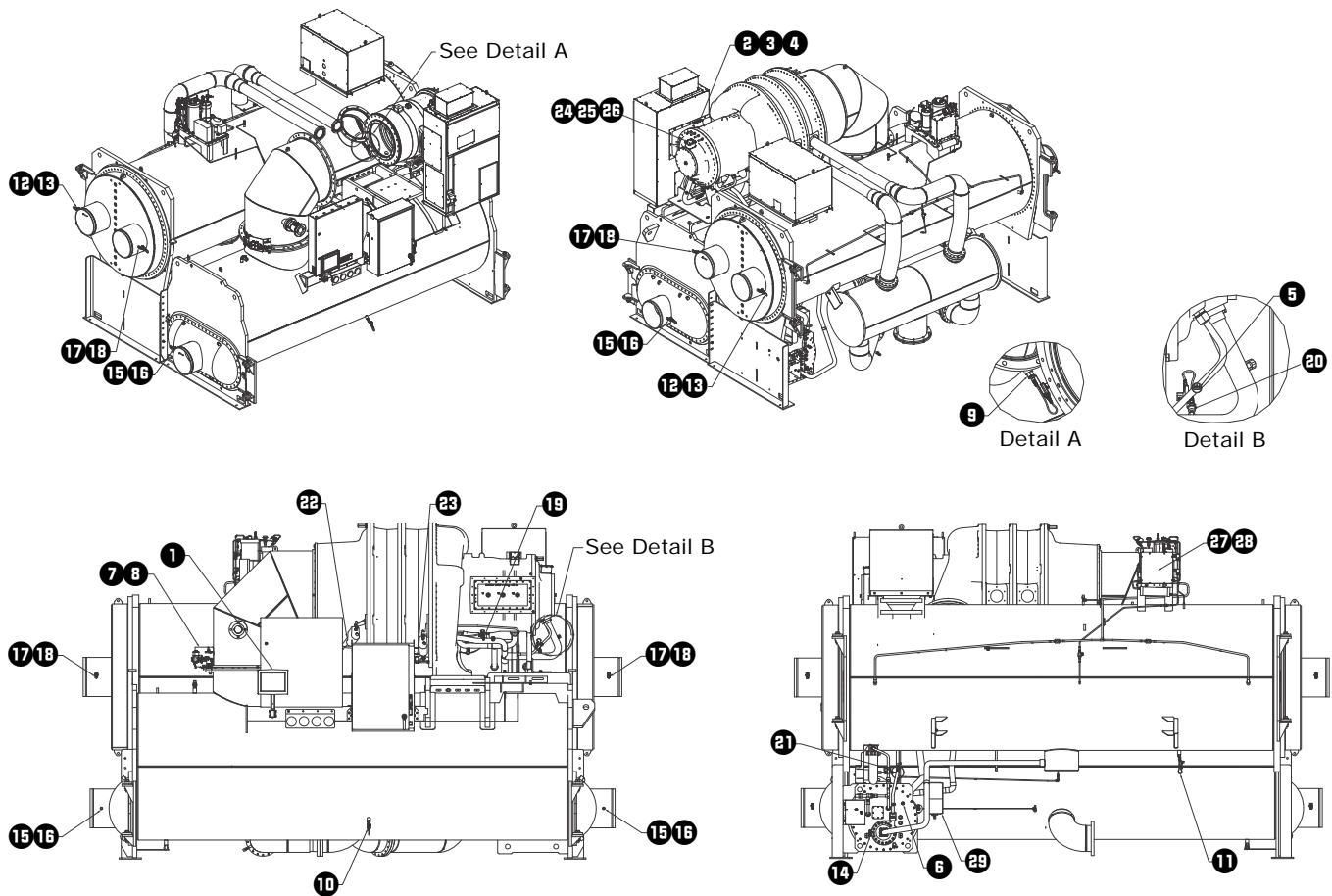

1. Tracer AdaptiView display module
2. Motor winding temperature 1
3. Motor winding temperature 2
4. Motor winding temperature 3
5. Oil pump discharge pressure transducer
6. Oil tank pressure transducer
7. Evaporator water differential pressure transducer
8. Condenser water differential pressure transducer
9. Compressor discharge refrigerant temperature sensor
10. Evaporator saturated refrigerant temperature sensor
11. Condenser saturated refrigerant temperature sensor
12. Second condenser entering water temperature sensor (used on HTRC)
13. Second condenser leaving water temperature sensor (used on HTRC)
14. Oil tank temperature sensor
15. Evaporator entering water temperature sensor

16. Evaporator leaving water temperature sensor
17. Condenser entering water temperature sensor
18. Condenser leaving water temperature sensor
19. Inboard bearing temperature sensor
20. Outboard bearing temperature sensor
21. Oil cooling solenoid valve
22. Inlet guide vane first stage actuator
23. Inlet guide vane second stage actuator
24. Outboard bearing pad temperature sensor 1
25. Outboard bearing pad temperature sensor 2
26. Outboard bearing pad temperature sensor 3
27. Condenser high pressure cut out switch
28. Condenser refrigerant pressure transducer
29. Oil tank vent line valve



System Control Circuit Wiring (Field Wiring)

CWR—Outdoor Option

The outdoor temperature sensor is similar to the unit-mounted temperature sensors in that it consists of the sensor probe and the module. A four-wire IPC bus is connected to the module for 24 Vdc power and the communications link. Trane recommends mounting the sensor module within the control panel and the sensor two wire leads be extended and routed to the outdoor temperature sensor probe sensing location. This ensures the four-wire IPC bus protection and provides access to the module for configuration at start-up.

The sensor probe lead wire between the sensor probe and the module can be separated by cutting the two-wire probe lead leaving equal lengths of wire on each device: the sensor probe and the sensor module.

Note: This sensor and module are matched and must remain together or inaccuracy may occur.

These wires can then be spliced with two 14–18 AWG 600V wires of sufficient length to reach the desired outdoor location with a maximum length 304.8 meters (1000 feet). For AWG/MCM equivalents in mm², refer to [Table 12, p. 47](#). The module four-wire bus must be connected to the control panel four-wire bus using the Trane-approved connectors provided.

The sensor will be configured (given its identity and become functional) at start-up when the Trane service technician performs the start-up configuration. It will NOT be operational until that time.

Note: If shielded cable is used to extend the sensor leads, be sure to cover the shield wire with tape at the junction box and ground it at the control panel. If the added length is run in conduit, do not run them in the same conduit with other circuits carrying 30 or more volts.

Important: Maintain at least 16 cm (6 in.) between low-voltage (<30V) and high voltage circuits. Failure to do so could result in electrical noise that may distort the signals carried by the low-voltage wiring, including the IPC.

Optional Control and Output Circuits

Install various optional wiring as required by the owner's specifications (see [Table 18, p. 65](#)).

Optional Tracer Communication Interface

This control option allows the control panel to exchange information—such as chiller status and operating set points—with a Tracer system.

Note: The circuit must be run in separate conduit to prevent electrical noise interference.

Additional information about the Tracer Communication interface option is published in the installation and operation guide that ships with the Tracer.

Unit Start-up/Commissioning

Important: Start-up must be performed by Trane or an agent of Trane specifically authorized to perform start-up and warranty of Trane® products. Contractor shall provide Trane (or an agent of Trane specifically authorized to perform start-up) with notice of the scheduled start-up at least two weeks prior to the scheduled start-up.

Starter Module Configuration

The starter module configuration settings will be checked (and configured for Remote Starters) during start-up commissioning.

Note: To configure starter modules, and perform other starter checks, it is recommended that the line voltage three-phase power be turned off and secured (locked out), and then that a separate source control power (115 Vac) be utilized to power up the control circuits.

Use the as-built starter schematic to ensure correct fuse and terminals. Verify that the correct fuse is removed and that the control circuit connections are correct; then apply the 115 Vac separate source power to service the controls.

Schematic Wiring Drawings

Please refer to the submittals and drawings that shipped with the unit. Additional wiring drawings for CenTraVac chillers are available from your local Trane office.

Operating Principles

General Requirements

Operation and maintenance information for CVHH chillers are covered in this section. This includes both 50 and 60 Hz centrifugal chillers equipped with the Tracer AdaptiView UC800 control system. This information pertains to all chiller types unless differences exist, in which case the sections are listed by chiller type as applicable and described separately. By carefully reviewing this information and following the instructions given, the owner or operator can successfully operate and maintain a CenTraVac unit. If mechanical problems do occur, however, contact a Trane service technician to ensure proper diagnosis and repair of the unit.

Cooling Cycle

When in the cooling mode, liquid refrigerant is distributed along the length of the evaporator and sprayed through small holes in a distributor (i.e., running the entire length of the shell) to uniformly coat each evaporator tube. Here, the liquid refrigerant absorbs enough heat from the system water circulating through the evaporator tubes to vaporize. The gaseous refrigerant is then drawn through the eliminators (which remove droplets of liquid refrigerant from the gas) and the first stage variable inlet guide vanes, and into the first-stage impeller.

CVHH 3-Stage Compressor

Compressed gas from the first-stage impeller flows through the fixed, second-stage inlet vanes and into the second-stage impeller. Here, the refrigerant gas is again compressed, and then discharged through the third-stage variable guide vanes and into the third-stage impeller. Once the gas is compressed a third time, it is discharged into the condenser. Baffles within the condenser shell distribute the compressed refrigerant gas evenly across the condenser tube bundle. Cooling tower water circulated through the condenser tubes absorbs heat from the refrigerant, causing it to condense. The liquid refrigerant then passes through an orifice plate and into the economizer.

The economizer reduces the energy requirements of the refrigerant cycle by eliminating the need to pass all gaseous refrigerant through three stages of compression (see Figure 35, p. 69). Notice that some of the liquid refrigerant flashes to a gas because of the pressure drop created by the orifice plates, thus further cooling the liquid refrigerant. This flash gas is then drawn directly from the first and second stages of the economizer into the third- and second-stage impellers of the compressor, respectively. All remaining liquid refrigerant flows through another orifice plate to the evaporator.

Figure 34. Pressure enthalpy curve, 3-stage

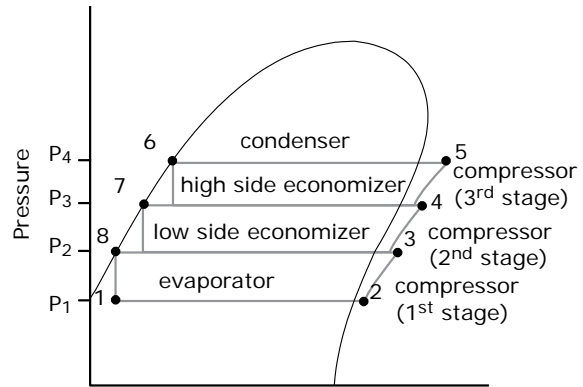
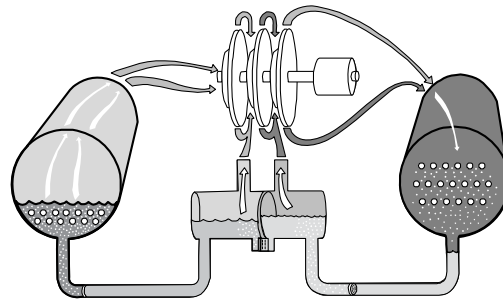

Figure 35. Refrigerant flow, 3-stage



CVHH 2-Stage Compressor

Compressed gas from the first-stage impeller is discharged through the second-stage variable guide vanes and into the second-stage impeller. Here, the refrigerant gas is again compressed, and then discharged into the condenser. Baffles within the condenser shell distribute the compressed refrigerant gas evenly across the condenser tube bundle. Cooling tower water, circulated through the condenser tubes, absorbs heat from the refrigerant, causing it to condense. The liquid refrigerant then flows out of the bottom of the condenser, passing through an orifice plate and into the economizer.

The economizer reduces the energy requirements of the refrigerant cycle by eliminating the need to pass all gaseous refrigerant through both stages of compression (see Figure 37). Notice that some of the liquid refrigerant flashes to a gas because of the pressure drop created by the orifice plate, thus further cooling the liquid refrigerant. This flash gas is then drawn directly from the economizer into the second-stage impellers of the compressor. All remaining liquid refrigerant flows through another orifice plate and into the evaporator.

Figure 36. Pressure enthalpy curve

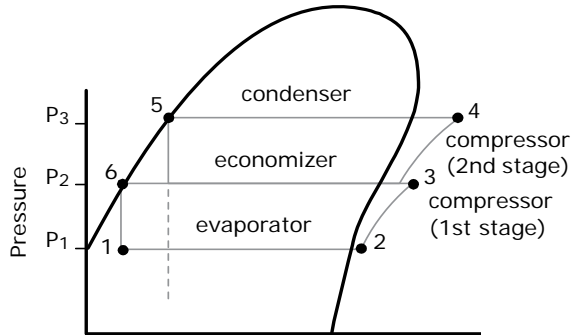
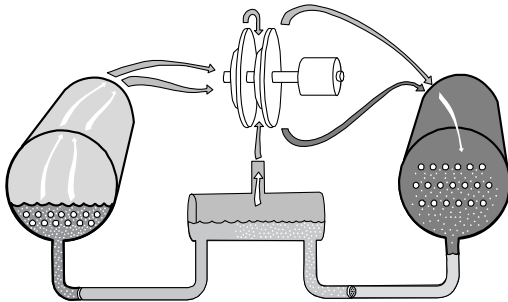

Figure 37. Refrigerant flow, 2-stage



Oil and Refrigerant Pump

Compressor Lubrication System

A schematic diagram of the compressor lubrication system is illustrated in [Figure 38, p. 71](#). Oil is pumped from the oil tank (by a pump and motor located within the tank) through an oil pressure regulating valve designed to maintain a net oil pressure of 137.9 to 165.5 kPaD (20 to 24 psid). It is then filtered and sent to the braze plate heat exchanger oil cooler located above the oil tank and on to the compressor motor bearings. From the bearings, the oil drains back to the oil tank.

Figure 38. Oil refrigerant pump

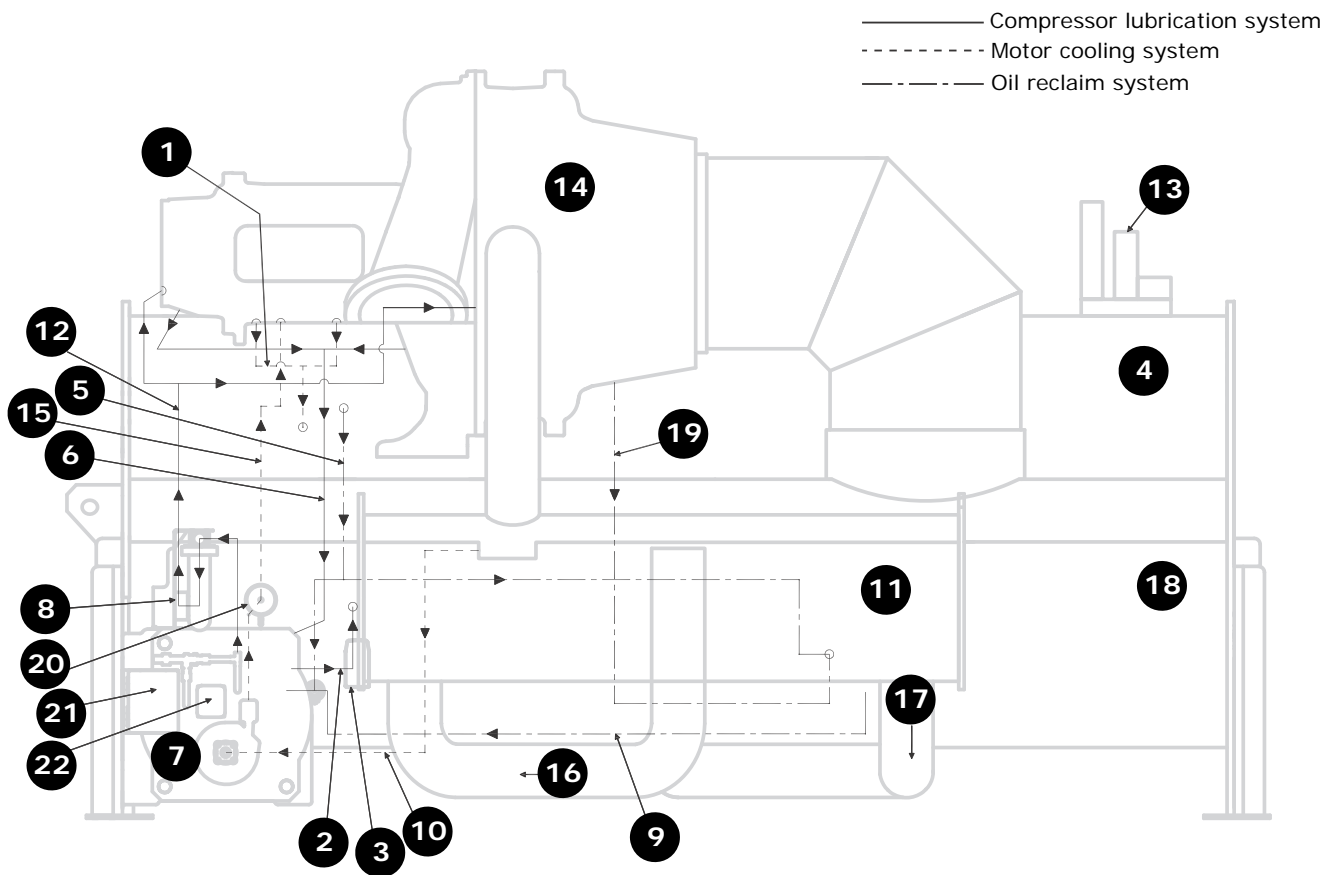

- | | |
|--|--|
| <ul style="list-style-type: none"> 1. Motor coolant return to condenser, 53.975 mm (2.125 in.) OD 2. Oil tank vent line, 53.975 mm (2.125 in.) OD 3. Vent line actuated ball valve 4. Condenser 5. High pressure condenser gas to drive oil reclaim eductors, 9.525 mm (0.375 in.) OD 6. Oil return to tank 7. Oil tank 8. Oil cooler braze plate heat exchanger 9. Oil reclaim from evaporator (2nd eductor), 6.35 mm (0.25 in.) OD 10. Liquid refrigerant to pump, 41.275 mm (1.625 in.) OD 11. Economizer | <ul style="list-style-type: none"> 12. Oil supply to bearings, 22.225 mm (0.875 in.) OD 13. Purge 14. Compressor 15. Liquid refrigerant motor coolant supply, 28.575 mm (1.125 in.) OD 16. Liquid refrigerant to economizer 17. Liquid refrigerant to evaporator 18. Evaporator 19. Oil reclaim from suction cover (1st eductor), 6.35 mm (0.25 in.) OD 20. Motor coolant filter 21. Oil tank junction box enclosure 22. Oil pump motor terminal box |
|--|--|

⚠ WARNING

Hot Surface!

Failure to use caution while working on the oil system could result in severe burns. Oil system temperature could exceed 65.6°C (150°F).

⚠ WARNING

Hazardous Voltage in Oil Tank Junction Box Enclosure and Oil Pump Motor Terminal Box!

Failure to disconnect main power and/or auxiliary control power before opening oil tank junction box enclosure or any other junction box/terminal box/panel on the CVHH and CDHH chiller can result in death or serious injury. Apply lockout/tagout devices and follow all company procedures for lockout/tagout. Unit must be tested to ensure a zero energy state and equipment must be put in an electrically safe work condition prior to maintenance. Hazardous voltage up to 600 Vac is present in the oil tank junction box enclosure and oil pump motor terminal box.



Note: Graphic labels (shown above) are used for CE application only.

Important:

- Before servicing, disconnect all power sources and allow at least 30 minutes for capacitors to discharge.
- All electrical enclosures—unit or remote—are IP2X.

To ensure proper lubrication and prevent refrigerant from condensing in the oil tank, two 750-watt heaters are in wells in the oil tank and are used to heat the oil while the unit is off. With the default settings, the oil heaters are de-energized when the unit starts. The heaters energize as needed to maintain 53.3°C to 56.1°C (128°F to 133°F) when the chiller is not running.

When the chiller is operating, the temperature of the oil tank is typically 37.8°C to 60.0°C (100°F to 140°F). The oil return lines are routed into a separation chamber in the oil tank. Gas flow exits out the top of the oil tank and is vented to the evaporator.

A dual eductor system, using high pressure condenser gas, reclaims oil from the suction cover and the evaporator. The suction cover eductor is discharged into the evaporator, and the evaporator eductor is discharged into the oil tank. The evaporator eductor line has a shut-off valve mounted on the evaporator. Normally, the valve should be 3/4 to one turn open; open up to two turns if necessary.

Oil supply to both the thrust bearing and journal bearings is cooled when the oil tank temperature reaches 60.0°C (140°F). The supply oil and liquid refrigerant are pumped to a brazed plate heat exchanger. The unit controller monitors oil tank temperature and opens a solenoid valve to allow liquid refrigerant to flow into the heat exchanger.

Motor Cooling System

Compressor motors are cooled with liquid refrigerant (see [Figure 38, p. 71](#)). The refrigerant pump is located on the front of the oil tank (motor inside the oil tank). The refrigerant pump inlet is connected to the well at the bottom of the condenser. The well design ensures preferential supply of liquid refrigerant to the refrigerant pump before refrigerant is supplied to the economizer. Refrigerant is delivered to the motor via the pump. An in-line filter is installed (replace the in-line filter only with major service). Motor refrigerant drain lines are routed to the condenser.

Tracer AdaptiView Display

Information is tailored to operators, service technicians, and owners.

When operating a chiller, there is specific information you need on a day-to-day basis—setpoints, limits, diagnostic information, and reports.

Day-to-day operational information is presented at the display. Logically organized groups of information—chiller modes of operation, active diagnostics, settings and reports put information conveniently at your fingertips. For more information, refer to *Tracer AdaptiView™ Display for Water-Cooled CenTraVac™ Chillers Operations Guide* (CTV-SVU01*-EN, or the most recent version).

RuptureGuard

The rupture disk monitors the pressure inside the chiller. If the pressure exceeds the disk's burst setting, the disk ruptures allowing the chiller pressure to enter the valve holder compartment upstream of the relief valve. If the pressure is above the pressure setting of the relief valve, the valve will open allowing only the amount of refrigerant to escape to keep the pressure within safe operating limits.

The excess flow valve maintains the downstream side of the rupture disk at atmospheric pressure to assure proper operating conditions for the disk. When the disk bursts, the rapid pressure increase causes the excess flow valve to seal and the valve holder area becomes pressurized.

A disk rupture will be indicated by a pressure reading on the gauge and the pressure switch contacts will close. The pressure switch is an optional accessory and does not wire to the control panel. The pressure switch can be connected to a customer-supplied building automation system (BAS).

EarthWise Purge

Centrifugal chillers that use low-pressure refrigerants, such as R-1233zd(E), operate with areas of the chiller at less than atmospheric pressure. Non-condensables in the air, such as water and nitrogen vapor, may leak into these low-pressure areas and accumulate in the condenser. If these non-condensables are not removed, the condenser loses its ability to condense refrigerant efficiently, and the pressure of the condenser increases. Increased condenser pressure lowers the chillers efficiency and capacity.

A purge system is required on low-pressure centrifugal chillers. It is a device that is externally mounted on the chiller. Its purpose is to remove non-condensable materials that have leaked into the machine.

Note: For convenience, the term "air" is often used in this document, although any other non-condensable materials that may exist in the chiller are also removed by the purge system.

How a Purge System Works

From a functional standpoint, the purge system can be divided into subsystems of components. This section identifies and describes the function of these subsystems.

Refrigeration Circuit Subsystem

The purge evaporator of the refrigeration circuit is located in the purge tank. The purge tank is connected to the chiller condenser by supply and return lines through which chiller refrigerant can freely flow.

The purge evaporator coil presents a cold condensing surface to the chiller refrigerant entering the purge tank. When the purge refrigeration system is running, refrigerant from the chiller condenser is attracted to the cold surface of the purge evaporator. When the gaseous refrigerant contacts the surface of the purge evaporator

coil, it condenses into a liquid, leaving a partial vacuum behind. More refrigerant vapor from the chiller condenser migrates to the purge tank to fill the vacuum.

The liquid refrigerant that has condensed in the purge tank returns to the chiller condenser through the liquid return line. The return line includes a filter-drier and a moisture-indicating sight glass.

The condensing unit is air-cooled, and is operable whether the chiller is running or not. No additional cooling source is required.

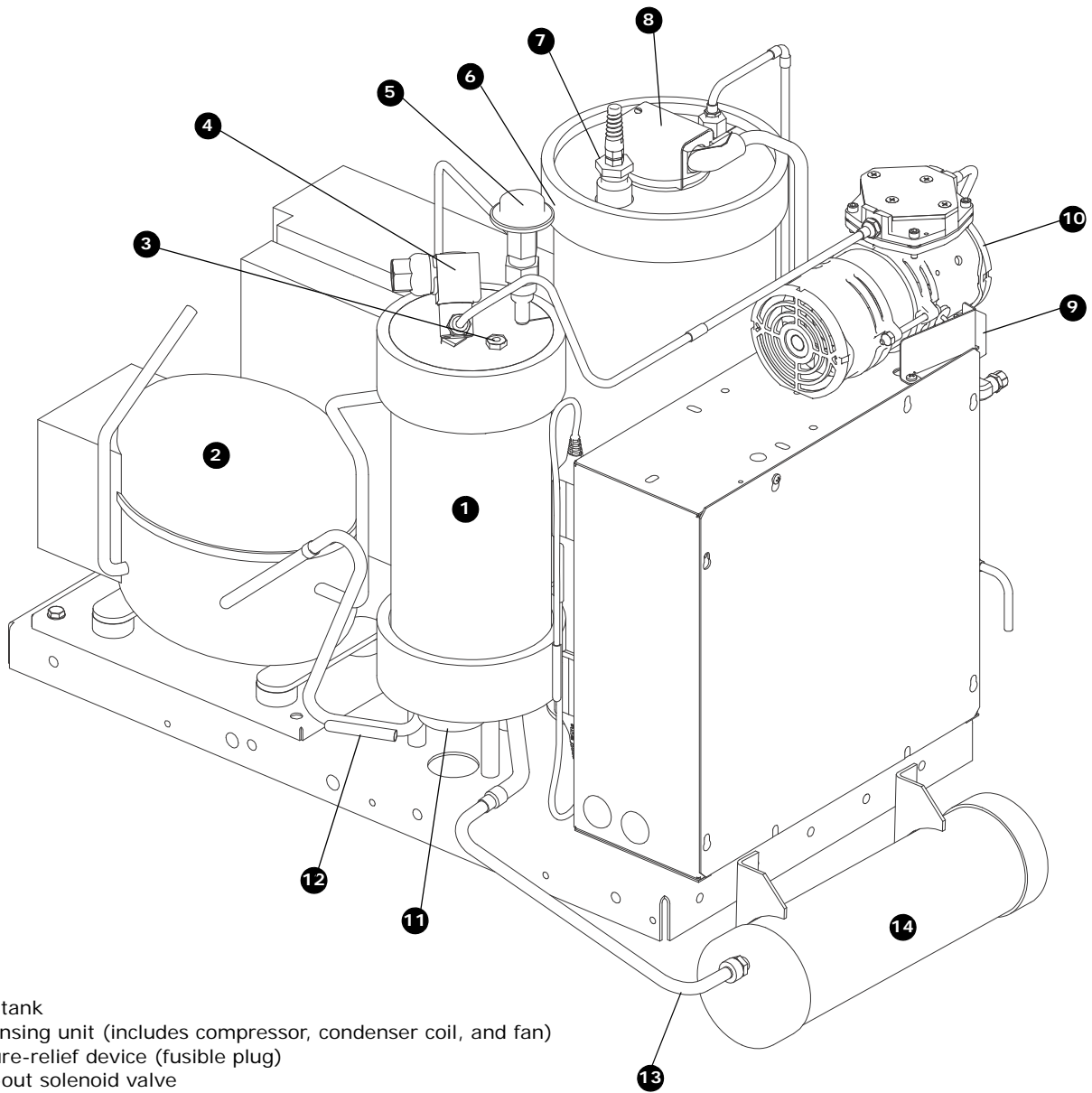
Figure 39. Components of a Trane EarthWise purge system (front view)

1. Purge tank
2. Condensing unit (includes compressor, condenser coil, and fan)
3. Pressure-relief device (fusible plug)
4. Pump-out solenoid valve
5. Automatic expansion valve
6. Carbon tank
7. Carbon tank temperature sensor
8. Carbon tank heater
9. Exhaust solenoid valve
10. Pump-out compressor
11. Float switch
12. Compressor suction temperature sensor
13. Chiller refrigerant return line
14. Filter-drier canister

Figure 40. Components of a Trane EarthWise purge system (back view)

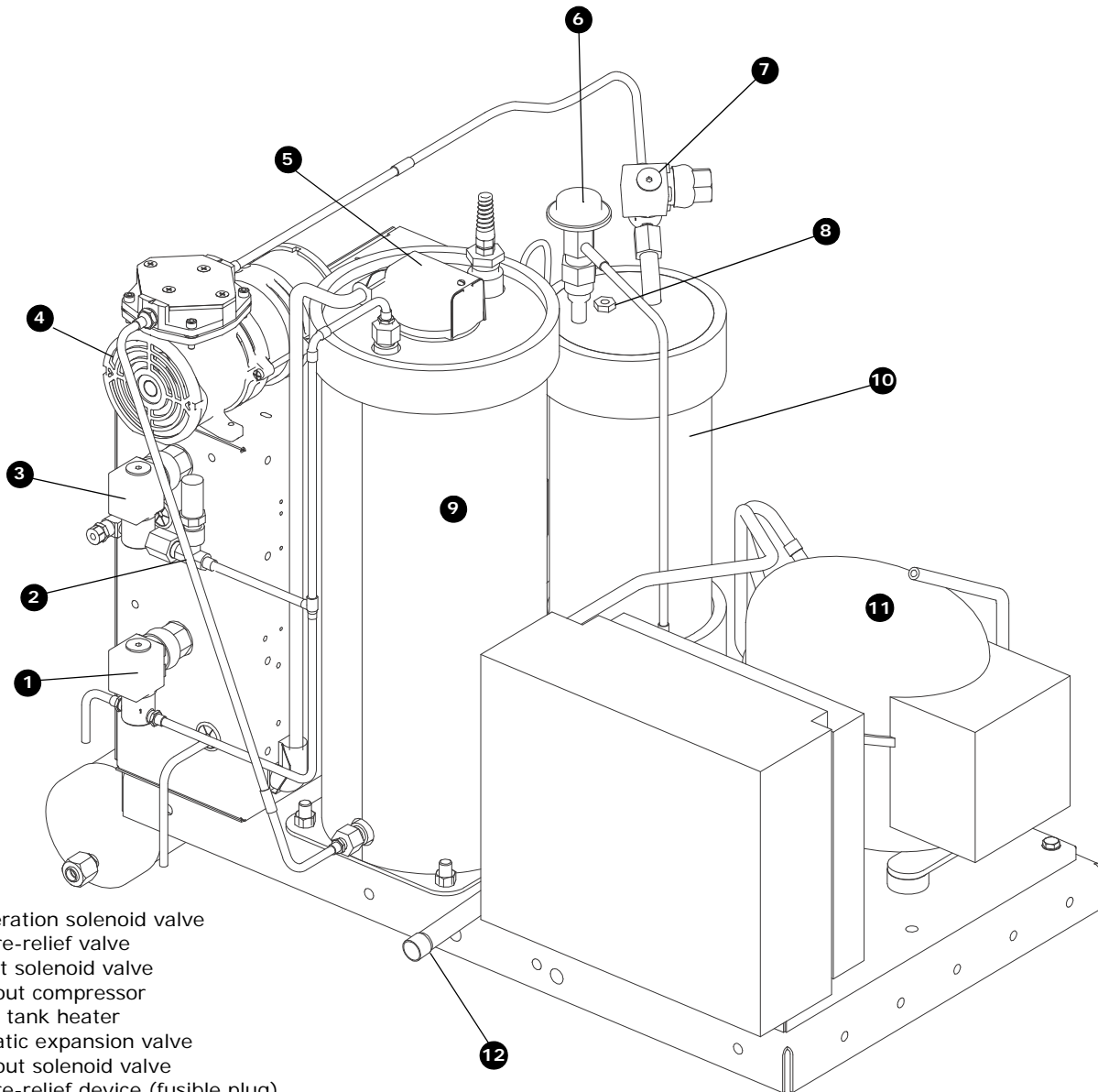

1. Regeneration solenoid valve
2. Pressure-relief valve
3. Exhaust solenoid valve
4. Pump-out compressor
5. Carbon tank heater
6. Automatic expansion valve
7. Pump-out solenoid valve
8. Pressure-relief device (fusible plug)
9. Carbon tank
10. Purge tank
11. Condensing unit
12. Chiller refrigerant supply line

Purge Tank Subsystem

Any non-condensables that have accumulated from the refrigerant vapor are left behind to collect in the purge tank. As the quantity of non-condensables increases, the heat transfer efficiency of the purge evaporator coil is reduced, causing the purge compressor suction temperature to decrease.

A float switch, mounted in the bottom of the purge tank, indicates if there is excessive accumulation of liquid refrigerant in the tank. A liquid level sensor, which resides

in the purge control panel, monitors the status of the float switch.

If the normally closed float switch is open for more than 20 minutes, the purge controls will turn off the refrigeration system and generate a non-latching diagnostic—Purge Liquid Level Too High Warning. If the float switch has re-closed after 20 minutes, the purge controls will restart the refrigeration system.

If the float switch remains open for more than 20 minutes, or if the float switch/liquid level restart cycle has occurred



Operating Principles

more than four times in four hours, a latching diagnostic—Purge Liquid Level Too High Continuously—will be generated. The purge system will not restart until it is reset.

If a Purge Liquid Level Too High Continuously diagnostic occurs, check the purge lines for any type of restriction (trapped liquid, closed valves, etc.) and ensure that the filter-drier on the liquid return line is in good condition.

A UL-required pressure-relief device (fusible plug), which protects against over-pressurization of the purge tank, is mounted on the purge tank. The plug material will fuse at 98.9°C (210°F), which equates to approximately 910.1 kPaG (132 psig) for refrigerant R-1233zd(E).

Pump-out Subsystem

When the purge control subsystem detects the presence of non-condensables in the purge tank, the pump-out solenoid and exhaust solenoid valves open, and the pump-out compressor turns on. The valves and the compressor cycle on and off as needed to achieve an efficient and fast removal of non-condensables.

A High Vacuum Pump option is available for applications that require purge operation at low condensing temperatures and pressures. This option provides a two-stage pump-out compressor. The High Vacuum Pump option allows the purge system to operate to saturation temperatures as low as 1.1°C (34°F). Typical applications that may require the High Vacuum Pump option include free-cooling installations, series chiller installations, ice systems having brine flowing through idle chillers, chillers installed outdoors or in unconditioned spaces, or any application that may cause very low condenser water temperatures.

Carbon Tank and Regeneration Subsystem

The discharge from the pump-out compressor is piped through the carbon tank. The special carbon in the tank effectively scrubs and collects refrigerant molecules from the non-condensable gas before the gas passes through the exhaust solenoid valve to the chiller vent line.

A 175 W resistive heater is mounted inside the carbon tank and is used to periodically “regenerate” the carbon bed and drive any collected refrigerant vapor back into the chiller. A UL-required pressure-relief valve, rated at 1034.2 kPaG (150 psig), is mounted on the line leaving the carbon tank. The valve protects against over-pressurization of the carbon tank.

A temperature sensor is installed through the top of the carbon tank shell so that the controls can monitor the carbon bed temperature. The temperature sensor controls the regeneration cycle and protect against overheating. If the limit temperature is reached, the system shuts down and a Purge Carbon Regen Temperature Limit Exceeded diagnostic is generated.

Sensors

The following sensors are used to enable control communication between the Tracer UC800 controller and the EarthWise purge system. The sensors use low-level intelligence devices (LLIDs) to communicate with the Tracer UC800 controller.

Compressor suction temperature sensor. This sensor is mounted on the purge condensing unit suction line. The controller uses the value of this temperature sensor to decide whether or not to purge non-condensables from the purge tank. When the temperature drops to a specified point, the controller activates the pump-out cycle to remove the accumulated non-condensables from the purge tank. When enough non-condensables have been removed and the purge compressor suction temperature increases in response, the controller terminates the pump-out cycle.

Saturated condenser temperature sensor. This sensor is mounted on the chiller. If the chiller is running, the controller uses the value of this temperature sensor to adjust the purge pump-out initiate/terminate setpoints. It may be used to prohibit pump-out, if system conditions are too cool.

Saturated evaporator temperature sensor. This sensor is mounted on the chiller. If the chiller is Off, the controller uses the value of this temperature sensor to adjust the purge pump-out initiate/terminate setpoints. It may be used to prohibit pump-out, if system conditions are too cool.

Carbon tank temperature sensor. This sensor is mounted in the carbon tank of the purge system. It provides feedback to the carbon regeneration algorithm. The sensor and the controller function much the same as a thermostat to control the carbon tank heater.

Liquid level sensor. This sensor resides in the purge control panel. It monitors the status of the normally closed float switch, which is mounted in the bottom of the purge tank. If an adequate amount of liquid fails to drain from the purge tank, the float switch and sensor detect the condition and prevent further purge operation.

Condensing unit LLID. This LLID resides in the purge control panel. It uses a high-capacity relay to control the operation of the purge condensing unit.

Quad relay LLID. This LLID resides in the purge control panel. It has four relay outputs that are used to control the pump-out compressor, the carbon tank heater, the regeneration solenoid valve, and an alarm output.

Dual triac LLID. This LLID resides in the purge control panel. It has two triac-type outputs that are used to control the pump-out solenoid valve and the exhaust solenoid valve. The purge system draws its control power from the power supplies of the chiller control panel.

Start-up and Shut-down

This section will provide basic information on chiller operation for common events. With microelectronic controls, ladder diagrams cannot show today's complex logic, as the control functions are much more involved than older pneumatic or solid state controls.

Chiller Sequence of Operation

Adaptive control algorithms can also complicate the exact sequence of operation. This section illustrates common control sequences.

Software Operation Overview Diagram

Figure 41 is a diagram of the five possible software states. This diagram can be thought of as a state chart, with the Figure 41. Software operation overview

arrows, and arrow text, depicting the transitions between states.

Descriptions

- The text in the circles are the internal software designations for each state.
- The first line of text in the circles are the visible top level operating modes that can be displayed on Tracer AdaptionView.
- The shading of each software state circle corresponds to the shading on the time lines that show the state that the chiller is in.

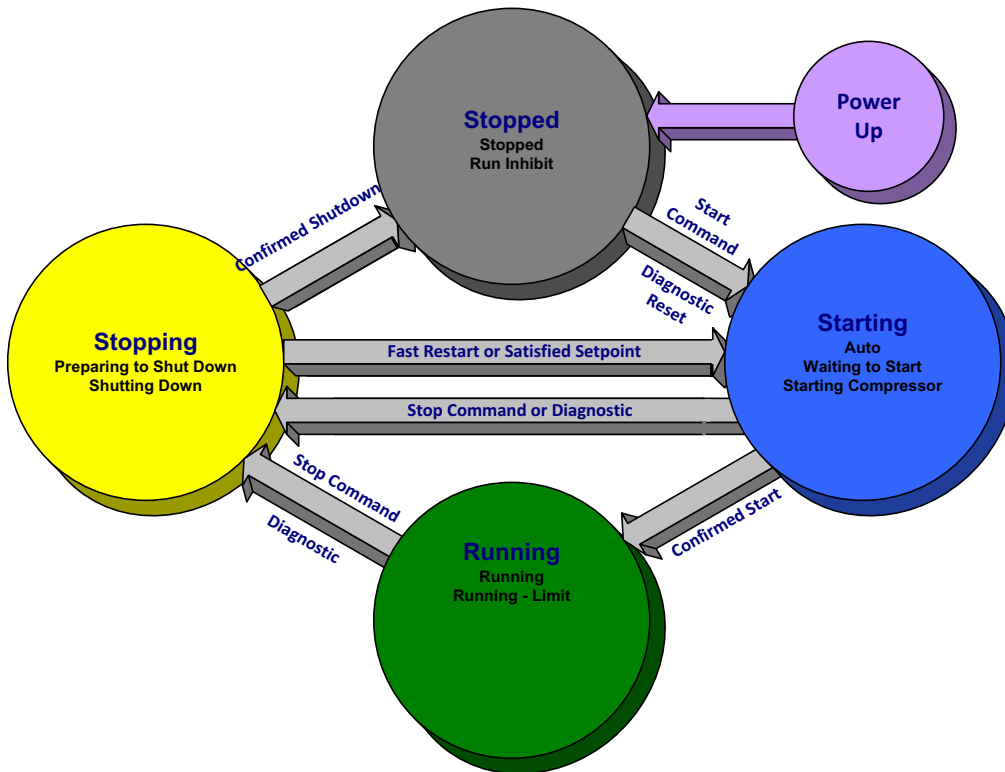

Start-up and Shut-down

There are five generic states that the software can be in:

- Power Up
- Stopped
- Starting
- Running
- Stopping

Descriptions

- The time line indicates the upper level operating mode, as it would be viewed on Tracer AdaptiView.
- The shading color of the cylinder indicates the software state.
- Text in parentheses indicates sub-mode text as viewed on Tracer AdaptiView.
- Text above the time line cylinder is used to illustrate inputs to the Main Processor. This may include User input to the Tracer AdaptiView Touch screen, Control inputs from sensors, or Control Inputs from a Generic BAS.
- Boxes indicate Control actions such as Turning on Relays, or moving the Inlet Guide Vanes.
- Smaller cylinders indicate diagnostic checks, text indicates time based functions, solid double arrows indicate fixed timers, and dashed double arrows indicate variable timers.

Start-up Sequence of Operation—Wye-Delta

Logic Circuits within the various modules will determine the starting, running, and stopping operation of the chiller. When operation of the chiller is required the chiller mode is set at "Auto." Using customer supplied power, the chilled water pump relay is energized and chilled water flow must be verified within 4 minutes and 15 seconds, at the same time the oil vent line valve is opened. The main processors logic decides to start the chiller based on the differential to start setpoint. With the differential to start criteria met, the module then energizes condenser water pump relay with customer supplied power (see Figure 42, p. 78).

Based on the Restart Inhibit function and the Differential to Start setpoint, the oil and refrigerant pump is energized, and the oil vent line valve is closed to the minimum position. The oil pressure must be at least 82.7 kPaD (12 psid) for 60 continuous seconds and condenser water flow verified within 4 minutes and 15 seconds for the compressor start sequence to be initiated. After the compressor starts, the oil vent line valve begins to open; it can take between 15 and 30 minutes to fully open depending on the chiller running conditions.

The compressor motor starts in the "Wye" configuration and then, after the compressor motor has accelerated and the maximum phase current has dropped below 85 percent of the chiller nameplate RLA for 1.5 seconds, the starter transitions to the "Delta" configuration.

Figure 42. Sequence of operation: power up to starting

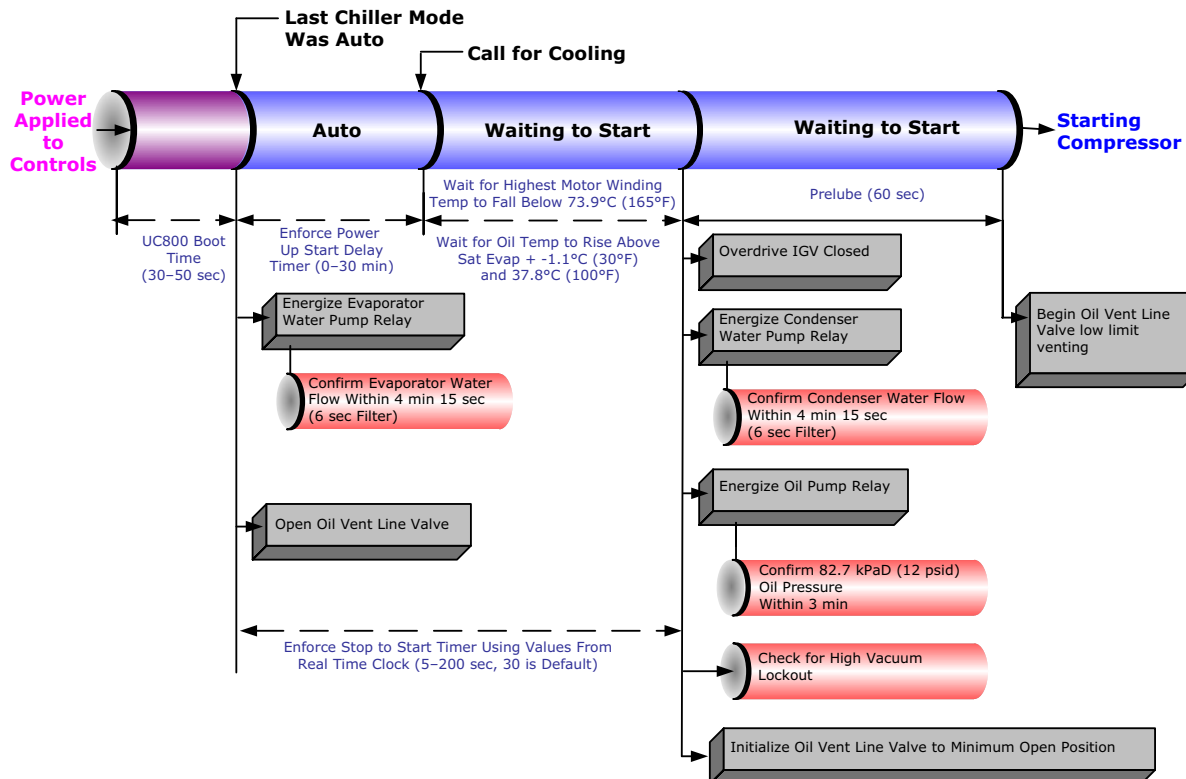

Now that the compressor motor is running in the “Delta” configuration, the inlet guide vanes will modulate, opening and closing to the chiller load variation by operation of the stepper vane motor actuator to satisfy chilled water setpoint. The chiller continues to run in its appropriate mode of operation: Normal, Softload, Limit Mode, and so on (see Figure 43). If the oil tank temperature rises above the oil cooler setpoint while the compressor is running, the oil cooler solenoid valve shall be energized to cool the oil.

If the chilled water temperature drops below the chilled water set point by an amount set as the “differential to stop” setpoint, a normal chiller stop sequence is initiated as follows:

1. The inlet guide vanes are driven closed (up to 50 seconds).
2. After the inlet guide vanes are closed, the stop relay and the condenser water pump relays open to turn off. The oil and refrigerant pump motor will continue to run for 3 minutes post-lube while the compressor coasts to a stop. The oil vent line valve will then open. The chilled water pump will continue to run while the main processor module monitors leaving chilled water temperature preparing for the next compressor motor start based on the “differential to start” setpoint.

Figure 44, p. 79 illustrates this sequence.

Figure 43. Sequence of operation: running

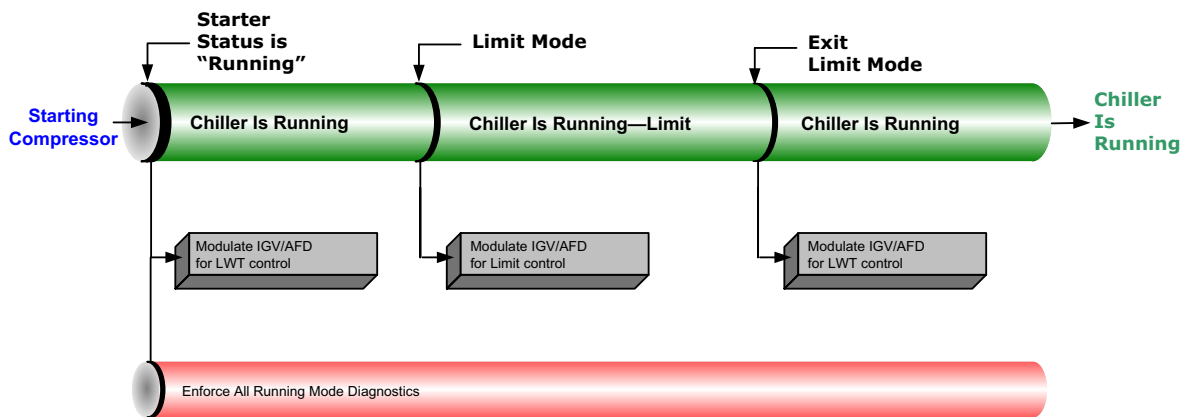

Note: If the Oil Tank Temperature rises above the Oil Cooler Control Setpoint while the compressor is running, the Oil Cooler Solenoid Valve shall be energized to cool the unit.

Figure 44. Sequence of operation: satisfied setpoint

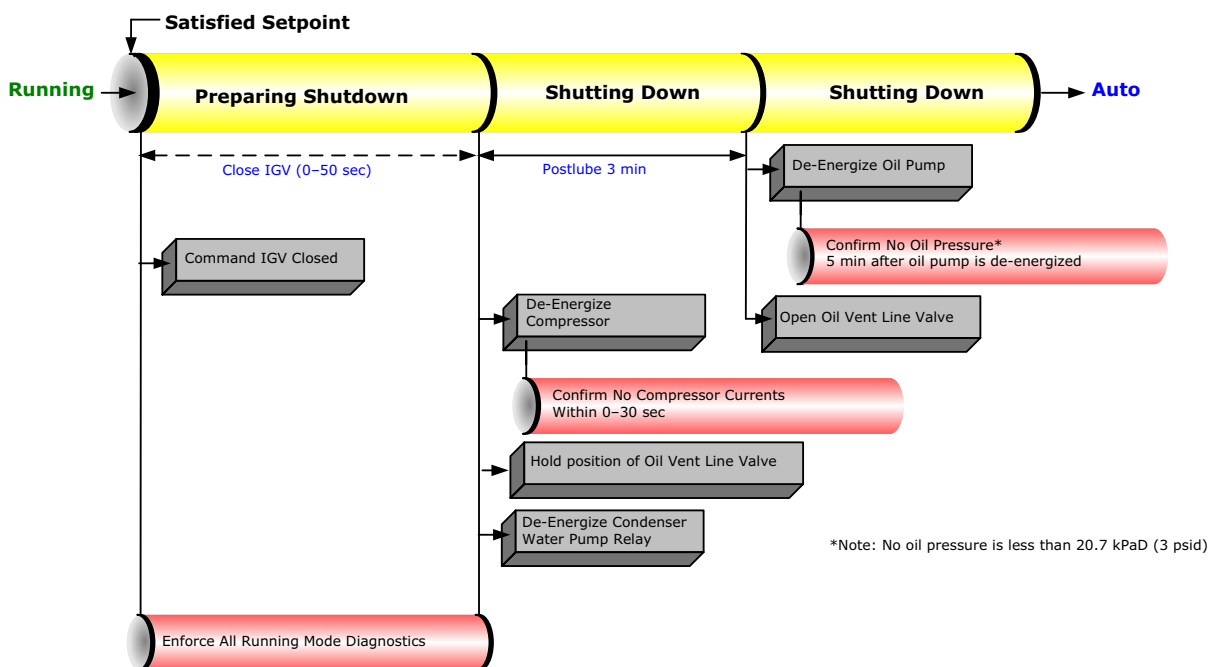

*Note: No oil pressure is less than 20.7 kPaD (3 psid)

Start-up and Shut-down

If the STOP key is pressed on the operator interface, the chiller will follow the same stop sequence as above except the chilled water pump relay will also open and stop the chilled water pump after the chilled water pump delay timer has timed out after compressor shut down (see Figure 45).

If the "Immediate Stop" is initiated, a panic stop occurs which follows the same stop sequence as pressing the STOP key once except the inlet guide vanes are not sequence closed and the compressor motor is immediately turned off.

Figure 45. Sequence of operation: normal shut-down to stopped and run inhibit

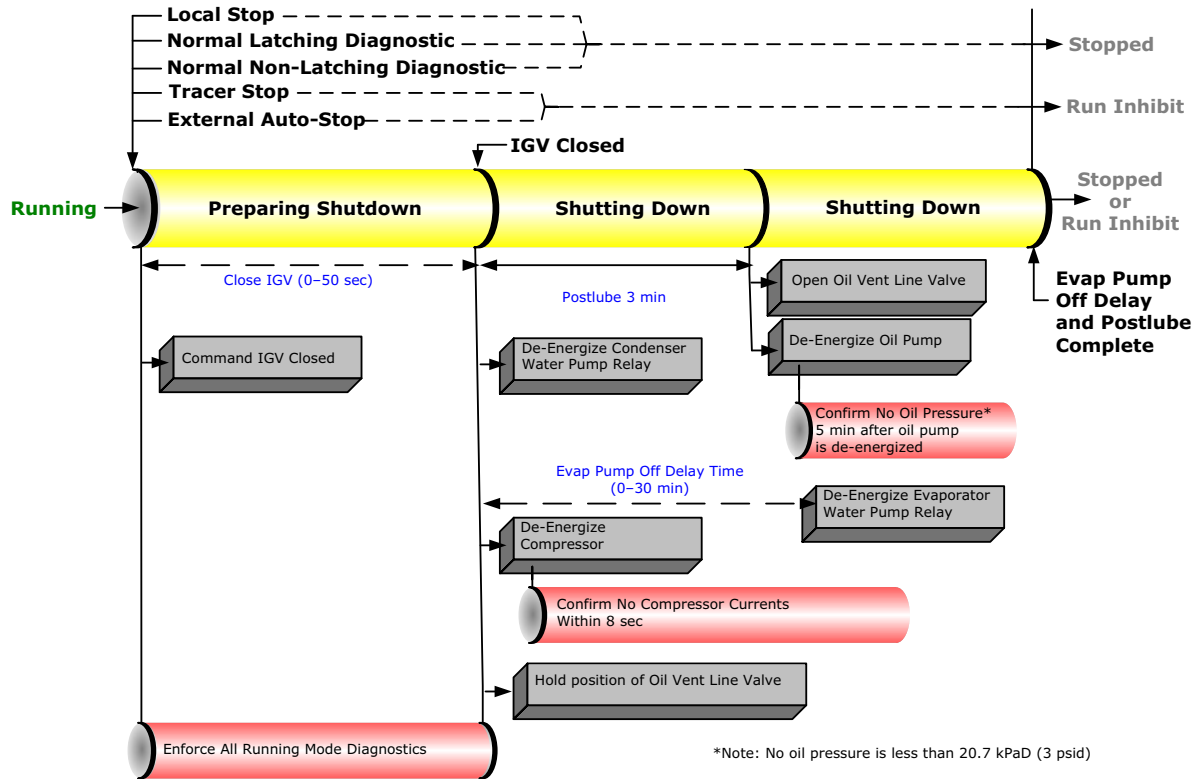

Power Up Diagram

Figure 42, p. 78 illustrates Tracer AdaptiView during a power up of the main processor. This process takes from 30 to 50 seconds depending on the number of installed Options. On all power ups, the software model always will transition through the Stopped software state independent of the last mode. If the last mode before power down was Auto, the transition from Stopped to Starting occurs, but it is not apparent to the user.

Ice Machine Control

The control panel provides a service level Enable or Disable menu entry for the Ice Building feature when the Ice Building option is installed. Ice Building can be entered from Front Panel, or if hardware is specified the control panel will accept either an isolated contact closure 1K9 Terminals J2-1 and J2-2 (Ground)) or a remote communicated input (BAS) to initiate the ice building mode where the unit runs fully loaded at all times. Ice building will be terminated either by opening the contact or based on entering evaporator fluid temperature. The control panel will not permit the Ice Building mode to be

entered again until the unit is switched to the non-ice building mode and back into the ice building mode. It is not acceptable to reset the chilled water setpoint low to achieve a fully loaded compressor. When entering ice building, the compressor will be loaded at its maximum rate and when leaving ice building the compressor will be unloaded at its maximum rate. While loading and unloading the compressor, all surge detection will be ignored. While in the ice building mode, current limit setpoints less than the maximum will be ignored. Ice Building can be terminated by one of the following means:

- Front panel disable.
- Opening the external Ice. Contacts/ Remote communicated input (BAS).
- Satisfying an evaporator entering fluid temperature setpoint (default is -2.8°C [27°F]).
- Surging for 7 minutes at full open IGV.

Figure 46. Sequence of operation: ice building: running to ice building

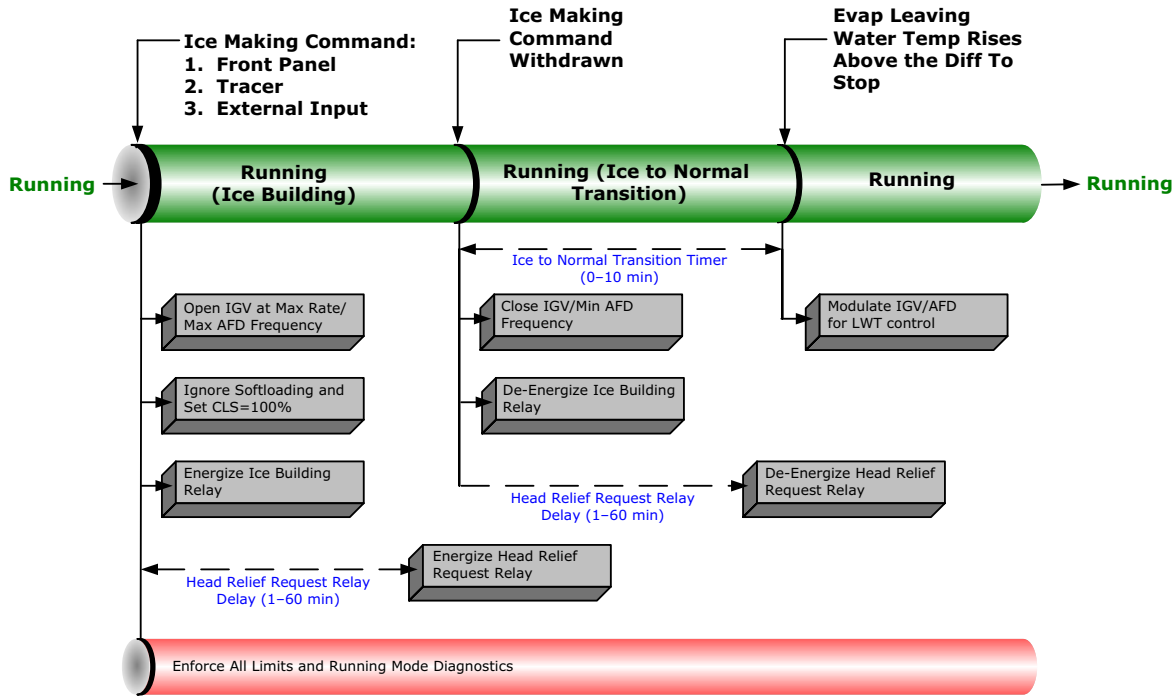
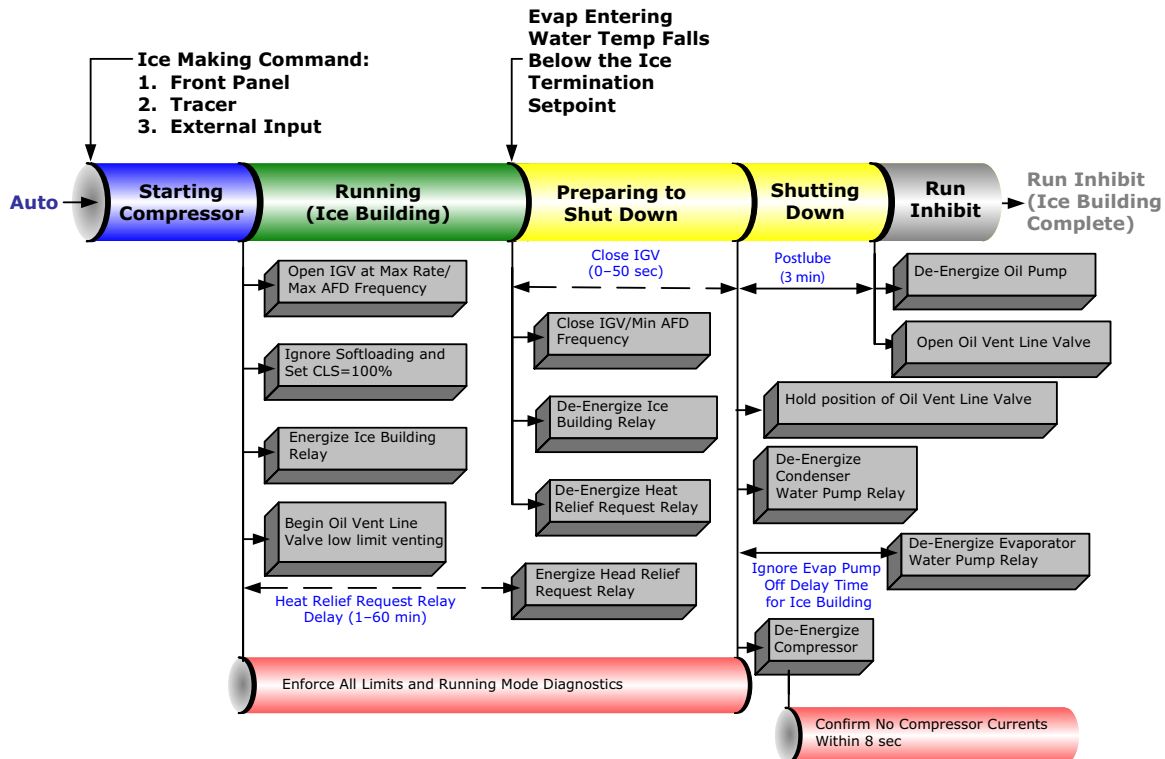

Figure 47. Sequence of operation: ice building: stopped to ice to ice building complete



Free Cooling Cycle

Based on the principle that refrigerant migrates to the coldest area in the system, the free cooling option adapts the basic chiller to function as a simple heat exchanger. However, it does not provide control of the leaving chilled water temperature.

If condenser water is available at a temperature lower than the required leaving chilled water temperature, the operator interface must remain in AUTO and the operator starts the free cooling cycle by enabling the Free cooling mode in the Tracer AdaptiView Feature Settings group of the operator interface, or by means of a BAS request. The following components must be factory-installed or field-installed to equip the unit for free cooling operation:

- a refrigerant gas line, and electrically-actuated shutoff valve, between the evaporator and condenser, and
- a valved liquid return line, and electrically-actuated shutoff valve, between the condenser sump and the evaporator.

When the chiller is changed over to the free cooling mode, the compressor will shut down if running, the shutoff valves in the liquid and gas lines open; unit control logic prevents the compressor from energizing during free cooling. Since the temperature and pressure of the refrigerant in the evaporator are higher than in the condenser (i.e., because of the difference in water temperature), the refrigerant in the evaporator vaporizes and travels to the condenser, cooling tower water causes the refrigerant to condense on the condenser tubes, and flow (again, by gravity) back to the evaporator.

This compulsory refrigerant cycle is sustained as long as a temperature differential exists between condenser and evaporator water. The actual cooling capacity provided by the free cooling cycle is determined by the difference between these temperatures which, in turn, determines the rate of refrigerant flow between the evaporator and condenser shells.

If the system load exceeds the available free cooling capacity, the operator must manually initiate changeover to the mechanical cooling mode by disabling the free cooling mode of operation. The gas and liquid line valves then close and compressor operation begins (see [Figure 42, p. 78](#), beginning at Auto mode). Refrigerant gas is drawn out of the evaporator by the compressor, where it is then compressed and discharged to the condenser.

Hot Water Control

Occasionally CTV chillers are selected to provide heating as a primary mission. With hot water temperature control, the chiller can be used as a heating source or cooling source. This feature provides greater application flexibility. In this case the operator selects a hot water temperature and the chiller capacity is modulated to maintain the hot water setpoint. Heating is the primary mission and cooling is a waste product or is a secondary mission. This type of operation requires an endless source

of evaporator load (heat), such as well or lake water. The chiller has only one condenser.

Note: Hot water temperature control mode does not convert the chiller to a heat pump. Heat pump refers to the capability to change from a cooling-driven application to a heating-driven application by changing the refrigerant path on the chiller. This is impractical for centrifugal chillers as it would be much easier to switch over the water side.

This is NOT heat recovery. Although this feature could be used to recover heat in some form, a heat recovery unit has a second heat exchanger on the condenser side.

The Tracer AdaptiView Main Processor provides the hot water temperature control mode as standard. The leaving condenser water temperature is controlled to a hot water setpoint between 26.7 and 60.0°C (80°F and 140°F). The leaving evaporator water temperature is left to drift to satisfy the heating load of the condenser. In this application the evaporator is normally piped into a lake, well, or other source of constant temperature water for the purpose of extracting heat. In hot water temperature control mode all the limit modes and diagnostics operate as in normal cooling with one exception; the leaving condenser water temperature sensor is an MMR diagnostic when in hot water temperature control mode. (It is an informational warning in the normal cooling mode.)

In the hot water temperature control mode the differential-to-start and differential-to-stop setpoints are used with respect to the hot water setpoint instead of with the chilled water setpoint. The control panel provides a separate entry at the Tracer AdaptiView to set the hot water setpoint. Tracer AdaptiView is also able to set the hot water setpoint. In the hot water mode the external chilled water setpoint is the external hot water setpoint; that is, a single analog input is shared at the 1K6-J2-5 to 6 (ground).

An external binary input to select external hot water control mode is on the EXOP OPTIONAL module 1K8 terminals J2-3 to J2-4 (ground). Tracer AdaptiView also has a binary input to select chilled water control or hot water temperature control. There is no additional leaving hot water temperature cutout; the HPC and condenser limit provide for high temperature and pressure protection.

In hot water temperature control the softloading pulldown rate limit operates as a softloading pullup rate limit. The setpoint for setting the temperature rate limit is the same setpoint for normal cooling as it is for hot water temperature control. The hot water temperature control feature is not designed to run with HGBP, AFD, free cooling, or ice building.

The factory set PID tuning values for the leaving water temperature control are the same settings for both normal cooling and hot water temperature control.

Control Panel Devices and Unit-Mounted Devices

Unit Control Panel

Safety and operating controls are housed in the unit control panel, the starter panel, and the purge control panel. The control panel operator interface and main processor is called Tracer AdaptiView and is located on an adjustable arm connected to the base of the control panel. For more information about operating Tracer AdaptiView, refer to *Tracer AdaptiView™ Display for Water-Cooled CenTraVac™ Chillers Operations Guide* (CTV-SVU01*-EN, or the most recent version).

The control panel houses several other controls modules called panel mounted LLID (Low Level Intelligent Device), power supply, terminal block, fuse, circuit breakers, and transformer. The IPC (Interprocessor communication) bus allows the communications between LLIDs and the main processor. Unit mounted devices are called frame mounted LLIDs and can be temperature sensors or pressure transducers. These and other functional switches provide analog and binary inputs to the control system.

User-Defined Language Support

Tracer AdaptiView is capable of displaying English text or any of twenty-four other languages. Switching languages is simply accomplished from a language settings menu.

Unit Start-up and Shut-down Procedures

⚠ WARNING

Live Electrical Components!

Failure to follow all electrical safety precautions when exposed to live electrical components could result in death or serious injury. During installation, testing, servicing and troubleshooting of this product, it may be necessary to work with live electrical components. Have a qualified licensed electrician or other individual who has been properly trained in handling live electrical components perform these tasks.

⚠ WARNING

Toxic Hazards!

Do not allow the chiller to increase above 54.4°C (130°F) in temperature while unit is off. Failure to prevent high chiller temperature will cause the inside pressure to rise:

- Do not run evaporator water pump longer than 30 minutes after the chiller is shut down.
- Ensure that the evaporator is isolated from the hot water loop before changeover to heating mode.

The rupture disk is designed to relieve and discharge the refrigerant from the unit if the pressure in the evaporator exceeds 344.7 kPaG (50 psig). A significant release of refrigerant into a confined space due to a rupture disk failure could displace available oxygen to breathe and cause possible asphyxiation. Should a rupture disk fail, evacuate the area immediately and contact the appropriate rescue or response authority. Failure to follow instructions could result in death or serious injury.



Note: Graphic labels (shown above) are used for CE application only.

Important:

- Before servicing, disconnect all power sources and allow at least 30 minutes for capacitors to discharge.
- All electrical enclosures—unit or remote—are IP2X.



Start-up and Shut-down

Daily Unit Start-up

1. Verify the chilled water pump and condenser water pump starter are in ON or AUTO.
2. Verify the cooling tower is in ON or AUTO.
3. Check the oil tank oil level; the level must be visible in or above the lower sight glass. Also, check the oil tank temperature; normal oil tank temperature before start-up is 53.3°C to 56.1°C (128°F to 133°F).
4. Check the chilled water setpoint and readjust it, if necessary, in the Chiller Settings menu.
5. If necessary, readjust the current limit setpoint in the Chiller Setpoints menu.
6. Press AUTO.

The control panel also checks compressor motor winding temperature, and a start is initiated after a minimum restart inhibit time if the winding temperature is less than 129.4°C (265°F). The chilled water pump relay is energized and evaporator water flow is proven. Next, the control panel checks the leaving evaporator water temperature and compares it to the chilled water setpoint. If the difference between these values is less than the start differential setpoint, cooling is not needed.

If the control panel determines that the difference between the evaporator leaving water temperature and chilled water setpoint exceeds the start differential setpoint, the unit enters the initiate Start Mode and the refrigerant pump and the condenser water pump are started. If flow is not initially established within 4 minutes 15 seconds of the condenser pump relay energization, an automatically resetting diagnostic "Condenser Water Flow Overdue" shall be generated which terminates the prestart mode and de-energizes the condenser water pump relay. This diagnostic is automatically reset if flow is established at any later time.

Note: This diagnostic does not automatically reset if Tracer AdaptiView is in control of the condenser pump through its condenser pump relay, since it is commanded off at the time of the diagnostic. It may reset and allow normal chiller operation if the pump was controlled from some external source.

If the compressor motor starts and accelerates successfully, Running appears on the display. If the purge is set to AUTO, the purge will start running and will run as long as the chiller is running.

Note: If a manual reset diagnostic condition is detected during start-up, unit operation will be locked out, and a manual reset is required before the start-up sequence can begin again. If the fault condition has not cleared, the control panel will not permit restart.

When the cooling requirement is satisfied, the control panel originates a Shutting down signal. The inlet guide vanes are driven closed for 50 seconds, the compressor stops, and the unit enters a 3-minute post-lube period. The

evaporator pump may continue to run for the amount of time set using Tracer AdaptiView.

Once the post-lube cycle is done, the unit returns to auto mode.

Seasonal Unit Start-up

1. Close all drain valves, and reinstall the drain plugs in the evaporator and condenser headers.
2. Service the auxiliary equipment according to the start-up and maintenance instructions provided by the respective equipment manufacturers.
3. Fill and vent the cooling tower, if used, as well as the condenser and piping. At this point, all air must be removed from the system (including each pass). Then close the vents in the condenser waterboxes.
4. Open all of the valves in the evaporator chilled water circuit.
5. If the evaporator was previously drained, fill and vent the evaporator and chilled water circuit. When all air is removed from the system (including each pass), close the vent valves in the evaporator waterboxes.
6. Lubricate the external vane control linkage as needed.
7. Check the adjustment and operation of each safety and operating control.
8. Close all disconnect switches.
9. Perform instructions listed in "Daily Unit Start-up," p. 84.

Daily Unit Shut-down

Note: Also refer to Figure 45, p. 80.

1. Press STOP.
2. After compressor and water pumps shut-down, the operator may turn Pump Contactors to OFF or open pump disconnects.

Seasonal Unit Shut-down

Important: Control power disconnect switch must remain closed to allow oil sump heater operation. Failure to do this will allow refrigerant to condense in the oil pump.

1. Open all disconnect switches except the control power disconnect switch.
2. Drain the condenser piping and cooling tower, if used. Rinse with clean water.
3. Remove the drain and vent plugs from the condenser headers to drain the condenser. Air dry bundle of residual water.
4. Once the unit is secured for the season, the maintenance procedures described Table 20, p. 94 and Table 21, p. 95 should be performed by qualified Trane service technicians.

Note: During extended shut-down periods, be sure to operate the purge unit for a two-hour period every

two weeks. This will prevent the accumulation of air and noncondensables in the machine. To start the purge, change the purge mode to ON in the unit control "Settings Purge" menu. Remember to turn the purge mode to "Adaptive" after the two-hour run time.

EarthWise Purge Sequence of Operations

A Tracer UC800 controller that is configured to control a purge system uses the operational sequences described in this section.

Purge Operating Modes

Purge operating mode options are as follows:

Stop. The purge condensing unit does not run in this mode.

On. The purge condensing unit runs continuously in this mode, regardless of the chillers operational status.

Auto. The purge condensing unit runs in this mode, if the main compressor of the chiller is operating.

Adaptive. The purge condensing unit operation depends on past purge activity.

Adaptive Mode

The objectives of operating the unit in the adaptive mode are to:

- Enable purge system operation
- Enable the refrigeration circuit to effectively accumulate non-condensables whether or not the chiller is running
- Provide information to an operator regarding whether leakage is on the high-pressure or low-pressure side of the chiller
- Decrease energy usage by running the purge refrigeration circuit only when needed to remove non-condensables, rather than running it continuously

The adaptive mode requires historical operating data so that the controller can make optimal decisions regarding how to run the purge refrigeration circuit in the future. On initial start-up of a chiller that is in adaptive mode, the purge refrigeration circuit runs continuously for 168 hours (7 days). The chiller compressor may or may not be running during this period.

Following the initial data collection period, the adaptive mode customizes the purge refrigeration circuit operation during two distinct chiller operating conditions:

- Chiller compressor On
- Chiller compressor Off

Adaptive Mode Process—Chiller Compressor On

Figure 48, p. 86, illustrates the process described in this subsection.

When the chiller compressor starts, the purge refrigeration circuit starts. The purge refrigeration circuit continues to run until 60 consecutive minutes of running occur without any pump-out of non-condensables. The Pumpout Time is the greater of the following two values that the controller has been tracking:

- The pump-out time with the chiller On, over the last 24 hours
- The average daily pump-out time with the chiller On, over the last 7 days

Figure 48. Adaptive chiller ON flow chart

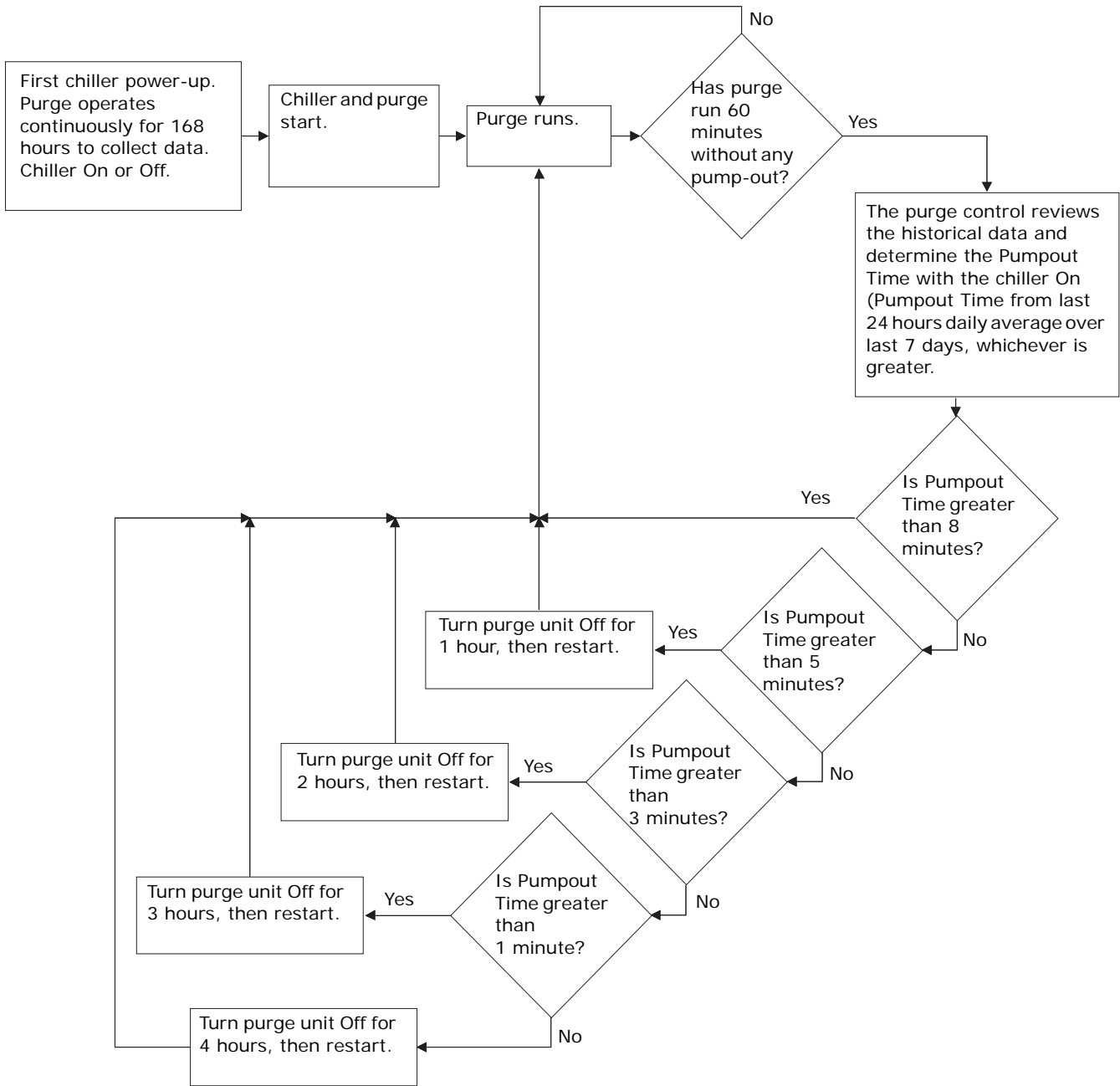

The purge then shuts down for a corresponding period of time, as shown in the following table:

Pumpout Time with chiller On (over the last 24 hours or daily average over the last 7 days, whichever is greater)	Purge Off cycle duration
Pumpout Time ≤ 1 minute	4 hours
1 minute < Pumpout Time ≤ 3 minutes	3 hours
3 minutes < Pumpout Time ≤ 5 minutes	2 hours
5 minute < Pumpout Time ≤ 8 minutes	1 hour
Pumpout Time > 8 minutes	No Off cycle

During the purge refrigeration circuit Off cycle, the time remaining is displayed as Time Until Next Purge Run in the Log Sheet that you can view from the Tracer AdaptiView display.

If the compressor is turned Off during the purge refrigeration circuit Off cycle, the purge transfers to Adaptive Mode Procedure—Chiller Compressor Off. [Figure 49, p. 88](#) illustrates this process.

Adaptive Mode Procedure—Chiller Compressor Off

Refer to [Figure 49, p. 88](#) for an illustration of the process described in this subsection.

If the chiller compressor is turned Off, the purge refrigeration circuit Off cycle is determined by the purge control. The purge Off-cycle duration is determined by the pump-out time, which is the greater of the following two values:

- Daily Pumpout—24 Hours (the pump-out time over the last 24 hours whether the chiller is On or Off)
- Average Daily Pumpout—7 Days (the pump-out time with the chiller On over the last 7 days)

Note: These two values can be seen on the Tracer AdaptiView display.

The purge will be shut down for a corresponding period of time, as shown in the following table:

The pump-out time with chiller On or Off (over the last 24 hrs or daily average over the last 7 days, whichever is greater)	Purge Off cycle duration
Pump-out time ≤ 1 minute	3 days
1 minute < pump-out time ≤ 3 minutes	2 days
3 minutes < pump-out time ≤ 5 minutes	1 day
Pump-out time > 5 minutes	6 hours

During the purge refrigeration circuit Off cycle, the time remaining is displayed as the Time Until Next Purge Run in the purge report of the Tracer AdaptiView display.

If the controls determine it is necessary to run the purge while the chiller compressor is Off, the purge will be started and run until 60 consecutive minutes have passed without any pump-out of non-condensables.

If the chiller compressor starts before the purge Off cycle has elapsed, the purge starts and transfers to Adaptive Mode Procedure—Chiller Compressor On. [Figure 48, p. 86](#), illustrates this process.

Submodes

You can view up to six purge submodes from the Purge Settings screen. The available purge submodes are:

Refrigeration Circuit On. appears if the purge condensing unit/compressor is operating.

Refrigeration Circuit Idle. appears if the purge condensing unit/ compressor is not operating.

Pumping Out. appears if the purge refrigeration circuit is On and pump-out has been initiated by the purge unit controls.

Exhaust Circuit Check. appears if a pump-out has been initiated by an operator.

Pumpout Inhibited. appears if the purge refrigeration circuit is On but pump-out has been inhibited by a low condenser saturation temperature.

Daily Pumpout Limit Disabled. appears if the purge refrigeration circuit is On but the daily pump-out limit has been disabled.

Regenerating. appears if the purge carbon system is in its regeneration mode. Pump-out is not allowed in this submode.

Alarm—Check Diagnostics. appears if a new diagnostic occurs.

Purge Diag Shutdown. appears if the purge system has shut down in response to a latching diagnostic.

Regen Disabled. appears if carbon regeneration is not allowed.

Figure 49. Adaptive chiller OFF flow chart

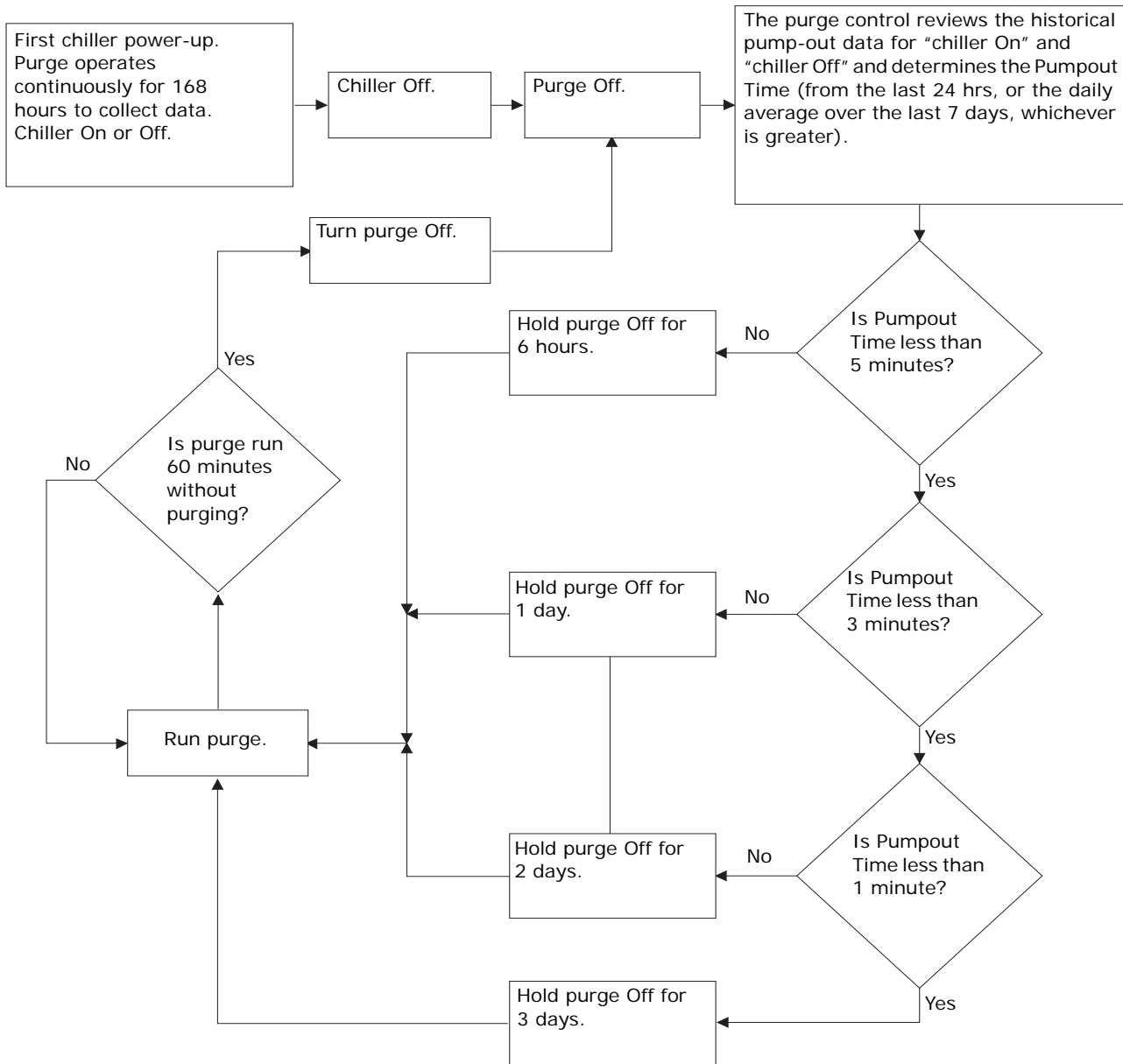

The purge condensing-unit compressor suction temperature varies with the amount of non-condensables collected in the purge tank. If the amount of non-condensables collected in the purge tank limits the available condensing surface in the tank, the condensing-unit compressor suction temperature begins to fall.

The purge controller initiates a pump-out cycle when the suction temperature reaches the pump-out initiate value that is calculated within the purge control. During the pump-out cycle, the small pump-out compressor pulls any non-condensables from the purge tank and discharges them through the carbon tank. As the non-condensables are removed from the purge tank, the condensing-unit compressor suction temperature increases. The purge

controller monitors the compressor suction temperature and cycles or stops the pump-out, depending on the temperature that is present.

The 1/4 hp air-cooled condensing unit of the refrigeration system operates effectively when it is in the operating range shown in [Figure 50](#).

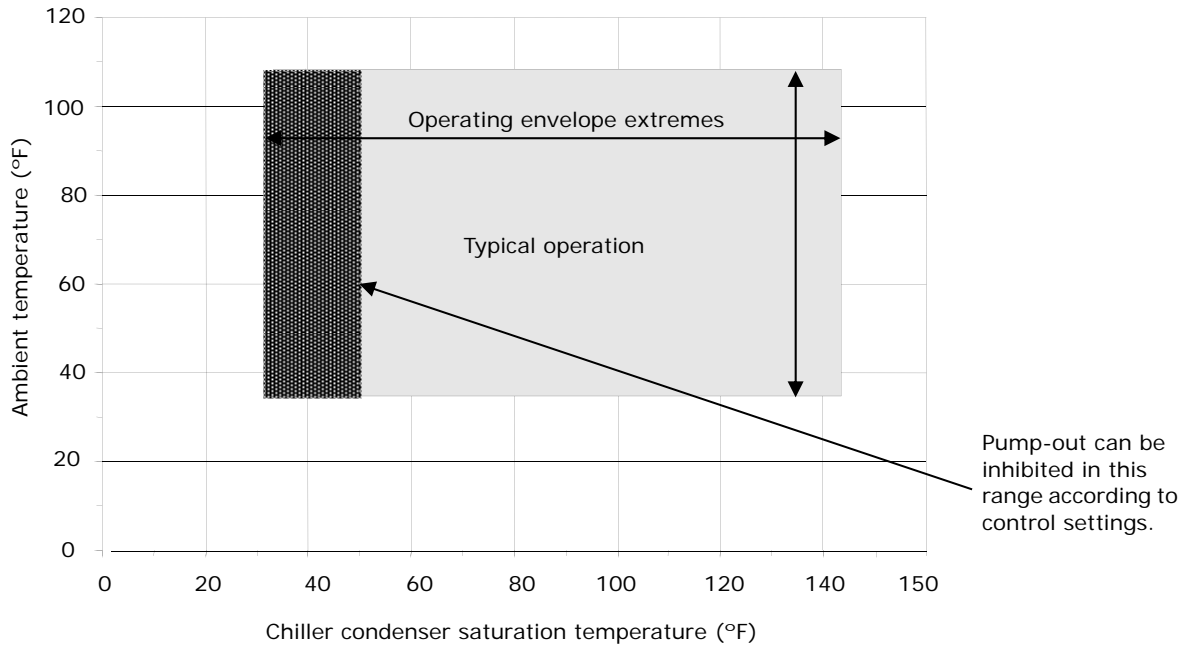
Figure 50. EarthWise purge operating limits

Air Removal

If no air is in the purge tank, the refrigerant returning to the purge condensing unit compressor suction has a high *superheat* (heat added past the point of evaporation), because of the heat removed from the condensing chiller refrigerant vapor in the purge tank. As air accumulates in the purge tank, it displaces the chiller refrigerant vapor and decreases the amount of coil surface that is exposed to the vapor. Less heat is removed from the vapor, and the available superheat at the purge condensing unit compressor suction consequently falls. When the purge refrigerant compressor suction temperature falls far enough to reach the pump-out initiate value, the purge control activates the solenoids and the pump-out compressor to remove the accumulated air.

As air is removed from the purge tank, the inside coil is once again exposed to chiller refrigerant vapor. As more chiller refrigerant vapor condenses on the coil, more heat is removed from the vapor, and the purge refrigerant compressor suction temperature rises. The purge control cycles or stops the pump-out process in response to the compressor suction temperature.

Pump-out Operating Sequence

As the purge control system detects the presence of non-condensables in the purge tank, it initiates a pump-out cycle. The pump-out solenoid valve, the exhaust solenoid valve, and the pump-out compressor cycle On and Off as needed to remove the non-condensables.

Non-Condensable Pump-out Algorithm

The controller uses the non-condensable pump-out algorithm to determine when to initiate, control, and

terminate a pump-out cycle to remove air from the purge tank. The purge refrigerant compressor suction temperature sensor serves as the feedback to this control algorithm. The compressor suction temperature pump-out initiate and pump-out terminate values are calculated by the purge control and are a function of the purge liquid temperature.

The refrigerant used in the purge refrigeration circuit, R-404A, is metered into the purge tank coil by a constant-pressure regulating expansion valve. The valve automatically controls the purge suction pressure at a constant value of 351.6 kPaA (51 psia). Therefore, refrigerant is metered into the coil as a two-phase refrigerant mixture at a constant saturation temperature of approximately -18.9°C (-2°F).

The cold coil creates a low vapor pressure near its outside surface, which draws refrigerant from the chiller condenser into the purge tank and to the coil surface. When the refrigerant gets close enough to the coil surface, it condenses into a liquid. Since liquid refrigerant requires less volume than it does in a gaseous form, additional refrigerant enters the purge tank to fill the void and, in turn, condenses. This mechanism is known as a *thermal siphon*.

As the chiller refrigerant condenses, heat is transferred into the purge coil through the latent heat of condensation. The compressor suction temperature sensor monitors this heat transfer.

Air and other gases carried with the chiller refrigerant vapor do not condense on the coil. Instead, they accumulate in the purge tank, effectively acting to insulate and inhibit the flow of refrigerant to the cold coil surface. The thermal siphon rate is reduced and, consequently, so is the amount of heat transfer. A corresponding reduction



Start-up and Shut-down

occurs in the temperature of the purge refrigerant exiting the coil. The compressor suction temperature sensor monitors this temperature.

When sufficient non-condensables have accumulated in the purge tank to decrease the compressor suction temperature below the pump-out initiate value, a pump-out cycle begins. The cycle is terminated when the compressor suction temperature sensor increases above the pump-out terminate value. The calculations for the pump-out values are:

Pump-out initiate:

- (°C) = Purge liquid temperature (°C) – 10.0°C or - 17.8°C (whichever is higher)
- (°F) = Purge liquid temperature (°F) – 50°F or 0°F (whichever is higher)

Pump-out terminate:

- (°C) = Purge liquid temperature (°C) – 4.4°C or - 15.0°C (whichever is higher)
- (°F) = Purge liquid temperature (°F) – 40°F or 5°F (whichever is higher)

The purge liquid temperature value comes from the chiller's saturated condenser temperature sensor when the chiller is running, or the chiller's saturated evaporator temperature sensor when the chiller is off.

Non-condensable Pump-out cycle

A non-condensable pump-out cycle may be initiated as described below only if the following two conditions are met:

- A carbon regeneration cycle is NOT in process, and
- The refrigeration circuit is on.

If at any time, except as described above, the purge refrigerant compressor suction temperature drops below the pump-out initiate value, the following sequence is initiated by the controls.

The controller starts the pump-out compressor and opens the exhaust solenoid valve. After 5 seconds, the pump-out solenoid valve opens and pulses at a rate of 20 seconds On and 20 seconds Off. If, after two cycles, the purge refrigerant compressor suction temperature has not exceeded the pump-out terminate value, the pump-out solenoid valve stays continuously open. If the pump-out compressor runs for more than 10 consecutive minutes, the controller recalculates the pump-out initiate and pump-out terminate values as described.

The purge controls continue to operate the pump-out solenoid valve and calculate values as described above until the purge refrigerant compressor suction temperature rises above the pump-out terminate value. At this point, the controller will close the pump-out solenoid valve and turn off the pump-out compressor and exhaust solenoid valve.

Note: For purge systems equipped with standard pump-out compressors, operation at low chiller

condenser saturation temperatures may result in a system vacuum greater than the pump-out compressor can overcome. If the chiller experiences low condensing temperatures, then the Tracer UC800 controller can be programmed to inhibit the operation of the purge pump-out compressor.

Carbon Tank and Regeneration Subsystem

The function of the carbon tank is to absorb refrigerant molecules that may be entrained in the discharge of non-condensables. In order to maintain effectiveness, the carbon tank periodically regenerates.

Carbon Regeneration Algorithm

The controller uses the carbon regeneration algorithm to determine when to initiate, control, and terminate a carbon regeneration cycle. The carbon bed temperature sensor serves as the feedback to this algorithm. In addition, the controller uses a pump-out accumulation timer to indicate the remaining carbon capacity in the carbon tank. The carbon capacity is the capacity of the carbon to adsorb refrigerant while maintaining acceptable levels of refrigerant emission through the chiller vent line. A capacity of 100 percent means the carbon bed has the capacity to adsorb refrigerant and maintain acceptable emission levels. A capacity of 0 percent means the carbon bed has inadequate capacity to adsorb refrigerant and still maintain acceptable emission levels.

The main objectives of the carbon regeneration algorithm are to:

- Minimize the amount of refrigerant contained in the carbon by performing a periodic regeneration.
- Regenerate to maintain low emissions levels.
- Minimize the regeneration time.
- Regenerate only when the chiller is at a minimum level of purging activity.
- Allow regeneration to occur with the chiller On or Off. Regeneration is preferable when the chiller is On to ensure low carbon tank pressure, but regeneration is also acceptable when the chiller is Off.

The remaining amount of absorption capacity within the carbon tank is directly proportional to the number of purge pump-out minutes that have accumulated, and is also a function of the chiller refrigerant type. The purge carbon tank on an R-1233zd(E)-equipped chiller is considered to be fully saturated after the purge has accumulated 350 minutes of pump-out time. Because the relationship between pump-out capacity and pump-out minutes is directly proportional, it can be described by the following equation within the regeneration algorithm:

Remaining carbon capacity% =

$100 - (\text{pump-out minutes since last regen/pump-out minutes at 100\% capacity}) * 100$

For example, an R-1233zd(E)-equipped chiller that has accumulated 80 minutes of purge pump-out time since the last carbon tank regeneration would be estimated to have 84 percent carbon tank capacity remaining:

$$100 - (80/350) * 100 = 84\%$$

The purge controls may initiate a carbon tank regeneration cycle when the remaining carbon tank capacity is calculated to be less than 80 percent. However, the continued stable operation of the chiller is always more important than the regeneration of the carbon tank. Therefore, the following rules apply:

1. If the Daily Pump-out Limit is disabled, a regeneration cycle may not be initiated, regardless of the value of the remaining carbon capacity.
Also, if the Daily Pump-out Limit is disabled during a regeneration cycle, the regeneration cycle must be terminated.
2. When the remaining carbon capacity is less than 80 percent, a regeneration cycle will be initiated at the next opportunity when the chiller is running (after the chiller has started and no pump-out minutes have accumulated for the previous 60 minutes).
3. If there is no opportunity to purge as indicated by Rules 1 and 2 and the remaining carbon capacity is less than 50 percent, a regeneration cycle will be initiated at the best opportunity when the chiller is shut down (and no pump-out minutes have accumulated for the previous 60 minutes).
4. If there is no opportunity to regenerate as indicated by Rules 1, 2, and 3, and the carbon capacity drops below 0 percent, then a regeneration cycle is initiated.
5. Note that if at any time during the regeneration cycle, the chiller is running and shuts down or if the chiller is off and starts up, then the regeneration cycle is continued.

Carbon Tank Regeneration Sequence

⚠ WARNING

Hazardous Voltage

Failure to disconnect power before servicing could result in death or serious injury. Disconnect all electric power, including remote disconnects before servicing. Follow proper lockout/ tagout procedures to ensure the power can not be inadvertently energized.



Note: Graphic labels (shown above) are used for CE application only.

Important:

- Before servicing, disconnect all power sources and allow at least 30 minutes for capacitors to discharge.
- All electrical enclosures—unit or remote—are IP2X.

If the purge controller determines that carbon tank regeneration is desired and is allowed, the purge controls:

1. Disable the purge refrigeration circuit and the pump-out solenoid valve.
2. Open the regeneration solenoid valve and turn on the carbon tank heater.
3. Monitor the carbon temperature until it reaches the regeneration temperature value of 115.6°C (240°F), and control within a ±5.6°C (±10°F) dead band for 15 minutes (this step should take approximately 3 hours).

Start-up and Shut-down

If the carbon tank temperature exceeds 120 percent of the regeneration temperature setpoint, the controller issues a latching diagnostic, Purge Carbon Regeneration Temperature Limit Exceeded. The purpose of this diagnostic is to identify a failed heater relay or temperature sensor. It disables the purge and opens the exhaust solenoid valve.

If the carbon tank temperature does not increase more than 13.3°C (56°F) in the first two hours, the controller generates a non-latching diagnostic, Carbon Regeneration Temperature Too Low. The purpose of this diagnostic is to identify a failed heater or temperature sensor. It prevents automatic regeneration from occurring, but a service technician can initiate a manual regeneration for testing purposes. All other purge algorithms continue to function.

If the carbon tank temperature does not reach the minimum regeneration temperature setpoint within 4 hours, the controller generates a non-latching diagnostic, Purge Carbon Regen Temperature Not Satisfied. The purpose of this diagnostic is to identify a failing insulation system.

The complete regeneration cycle can take as long as seven hours to accomplish, but an average chiller does not have to regenerate very often. A typical regeneration cycle is depicted in [Figure 51](#).

Figure 51. Typical carbon regeneration cycle

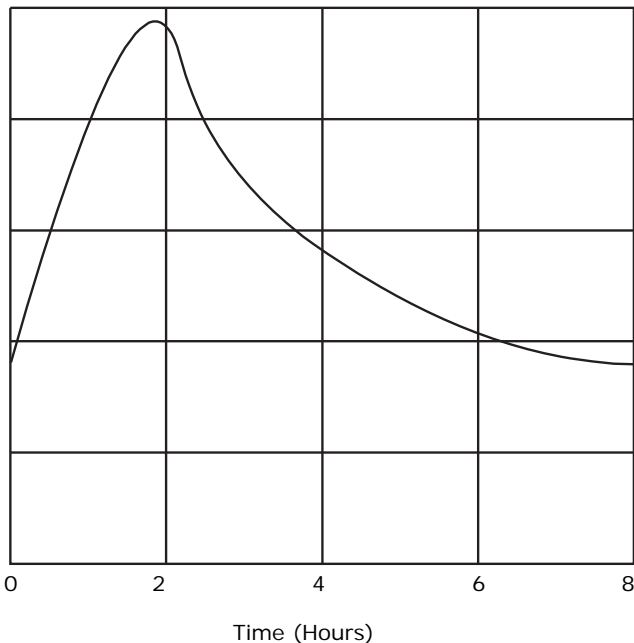

Purge Status Points

The status points appear on the purge component screen of the Tracer AdaptiView display. The purge component screen is accessible from the purge touch target on the home screen of the display.

Time Until Next Purge Run. Displayed if the purge is in Adaptive mode and is idle. It indicates the amount of time left on the adaptive cycle timer.

Daily Pumpout—24 Hours. Indicates the daily pumpout time for the last 24 hours (a moving 24-hour window). It indicates how the hermetic integrity of the chiller compares to historic pump-out times for the same chiller. It also allows a check against factory-recommended values.

Average Daily Pumpout—7 Days. Indicates the average daily pump-out time for the last 168 hours (a moving 168-hour window). Enables a comparison of present pump-out times to past averages, and can be another indication of the hermetic integrity of the chiller.

Daily Pumpout Limit/Alarm. Indicates the limit value that an operator has set in the Settings menu. When the daily pumpout rate exceeds this value, purge operation stops and a diagnostic is generated.

Chiller On—7 Days. Indicates the percentage of time during the past 7 days (floating 168-hour window) that the chiller was operating. You can use it to help determine if a leak is present on the high side or the low side of the chiller.

Pumpout Chiller On—7 Days. Indicates the percentage of the total purge pump-out time during the past 7 days that occurred while the chiller was operating. You can use it to help determine if a leak is present on the high side or the low side of the chiller.

Pumpout Chiller Off—7 Days. Indicates the percentage of the total purge pump-out time during the past 7 days that occurred when the chiller was not operating. You can use it to help determine if a leak is present on the high side or the low side of the chiller.

Pumpout—Life. Indicates the total purge pump-out time that has accumulated over the life of the purge.

Purge Rfgr Suction Temp. Indicates the purge refrigerant compressor suction temperature. It is useful for diagnosing purge system problems.

Purge Liquid Temp. Indicates the temperature sensed by the controller and used to inhibit purge operation. The purge liquid temperature sensor, when the chiller is operating, is the chiller saturated condenser temperature sensor; when the chiller is Off, it is the chiller saturated evaporator temperature sensor. If this temperature is below the Pumpout Inhibit Temperature that is defined in the Settings menu, pump out is not allowed. This value is used to prevent inefficient operation of the purge under certain conditions.

Carbon Tank Temp. Indicates the carbon bed temperature and is useful for monitoring regeneration and for diagnosing regeneration system problems.

Recommended Maintenance

⚠ WARNING

Hazardous Voltage w/Capacitors!

Failure to disconnect power and discharge capacitors before servicing could result in death or serious injury. Disconnect all electric power, including remote disconnects and discharge all motor start/run capacitors before servicing. Follow proper lockout/tagout procedures to ensure the power cannot be inadvertently energized. For variable frequency drives or other energy storing components provided by Trane or others, refer to the appropriate manufacturer's literature for allowable waiting periods for discharge of capacitors. Verify with an appropriate voltmeter that all capacitors have discharged.

For additional information regarding the safe discharge of capacitors, see PROD-SVB06-EN*

NOTICE:

Check Purge Run-Time for Unit Hermetic Integrity!

If frequent purging is required, failure to monitor purge pumpout rate, identify and correct source of air or water leak as soon as possible could shorten chiller life expectancy, due to moisture contamination caused by leakage.

NOTICE:

Do Not Use Non-Compatible Parts or Materials!

Use of non-compatible parts or materials could result in equipment damage. Only genuine Trane® replacement components with identical Trane part numbers should be used in Trane CenTraVac chillers. Trane assumes no responsibility for damages resulting from the use of non-compatible parts or materials.

This section describes the basic chiller preventive maintenance procedures, and recommends the intervals at which these procedures should be performed. Use of a periodic maintenance program is important to ensure the best possible performance and efficiency from a CenTraVac chiller.

Note: Due to the pressure vessel codes applied to CVHH CenTraVac chillers, the bolts used for both the economizer sump cover and the oil tank cover are specified for both ASME and PED application (SCREW, METRIC CAP-M16 x 70 mm with FULL THREAD), HEAVY HEXAGON HEAD - ASME SA-193M GRADE B7, ZINC PLATED. Do not substitute! Contact your local Trane representative for replacement bolts.

Record Keeping Forms

An important aspect of the chiller maintenance program is the regular completion of records. Refer to "[Forms and Check Sheets](#)," p. 104 for copies of the recommended forms. When filled out accurately by the machine operator, the completed logs can be reviewed to identify any developing trends in the chiller's operating conditions. For example, if the machine operator notices a gradual increase in condensing pressure during a month's time, he can systematically check, then correct the possible cause of this condition.



Note: Graphic labels (shown above) are used for CE application only.

Important:

- Before servicing, disconnect all power sources and allow at least 30 minutes for capacitors to discharge.
- All electrical enclosures—unit or remote—are IP2X.



Recommended Maintenance

Normal Operation

Table 19. Normal operation

Operating Characteristic	Normal Reading
Approximate Evaporator Pressure	55.2 to 91.0 kPaA (8 to 13.2 psia) / -46.2 to -10.3 kPaG (-6.7 to -1.5 psig)
Approximate Condenser Pressure ^(a)	166.9 to 259.9 kPaA (24.2 to 37.7 psia) / 65.5 to 158.6 kPaG (9.5 to 23 psig) (standard condenser)
Oil Sump Temperature Unit not running	43.3°C to 57.2°C (110°F to 135°F)
Oil Sump Temperature Unit running	43.3°C to 71.1°C (110°F to 160°F)
Oil Sump Differential Oil Pressure ^(b)	137.9 to 165.5 kPaD (20 to 24 psid)

(a) Condenser pressure is dependent on condenser water temperature, and should equal the saturation pressure of R-1233zd(E) at a temperature above that of leaving condenser water at full load.

(b) Oil tank pressure: -48.3 to -27.6 kPaG (-7 to -4 psig). Discharge oil pressure: 89.6 to 137.9 kPaG (13 to 20 psig).

NOTICE:

Equipment Damage!

Failure to remove the strain relief with the sensor could result in equipment damage. Do NOT attempt to pull sensor bulb through the strain relief; always remove the entire strain relief with the sensor.

Table 20. Recommended maintenance

Daily	Every 3 months	Every 6 months	Annually ^{(a), (b)}
Check the chiller's evaporator and condenser pressures, oil tank pressure, differential oil pressure and discharge oil pressure. Compare the readings with the values provided in Table 19, p. 94 .			
Check the oil level in the chiller oil sump using the two sight glasses provided in the oil sump head. When the unit is operating, the oil level should be visible in the lower sight glass.			
Complete logs on a daily basis.	Clean all water strainers in the water piping system.	Lubricate the vane control linkage bearings, ball joints, and pivot points.	
		Lubricate vane operator tang O-rings.	
		Operate the tang operators manually and check for any abnormalities.	
		Drain contents of the rupture disk and purge discharge ventline drip-leg into an evacuated waste container. Do this more often if the purge is operated excessively. Apply oil to any exposed metal parts to prevent rust.	
			Shut down the chiller once each year to check the items listed on the "CVHH Annual Inspection List" (refer to "Forms and Check Sheets," p. 104).
			Perform the annual maintenance procedures referred to in "EarthWise Purge Maintenance," p. 96.
			Use an ice water bath to verify the accuracy of the evaporator refrigerant temperature sensor (4BT11). If the sensor is exposed to temperature extremes outside its normal operating range (-17.8°C to 32.2°C [0°F to 90°F]), check its accuracy at six-month intervals.
			Inspect the condenser tubes for fouling; clean if necessary.

Table 20. Recommended maintenance (continued)

	Inspect and clean the ifm efector [®] flow detection sensors. Use Scotch-Brite [®] or other non-abrasive material to clean scale; do NOT use steel wool, which could cause the probe to rust.
	Submit a sample of the compressor oil to a Trane-qualified laboratory for comprehensive analysis.
	Measure the compressor motor winding resistance to ground; a qualified service technician should conduct this check to ensure that the findings are properly interpreted. Contact a qualified service organization to leak-test the chiller; this procedure is especially important if the system requires frequent purging.
<p>(a) Every three years, use a nondestructive tube test to inspect the condenser and evaporator tubes. It may be desirable to perform tube tests on these components at more frequent intervals, depending upon chiller application. This is especially true of critical process equipment.</p> <p>(b) Contact a qualified service organization to determine when to conduct a complete examination of the unit to discern the condition of the compressor and internal components. Check the following: chronic air leaks (which can cause acidic conditions in the compressor oil and result in premature bearing wear) and evaporator or condenser water tube leaks (water mixed with the compressor oil can result in bearing pitting, corrosion, or excessive wear).</p>	

Table 21. Recommended maintenance of optional features

Feature	Every 3 months	Every 6 months	Annually
Waterbox Coatings	Inspect waterbox coatings within the first 1–3 months to determine a required maintenance schedule for your job site. Refer to “Waterbox and Tubesheet Protective Coatings,” p. 99 for more information.		
Waterbox Anodes	Inspect waterbox anodes within the first 1–3 months to determine a required maintenance schedule for your job site. Refer to “Sacrificial Anodes,” p. 99 for more information.		
Gantries			Lubricate the gantries annually. Use ConocoPhillips MegaPlex [®] XD3 (gray in color), LPS [®] MultiPlex Multi-Purpose (blue in color), or equivalent.
Hinges			Lubricate the hinges annually. Use ConocoPhillips MegaPlex [®] XD3 (gray in color), LPS [®] MultiPlex Multi-Purpose (blue in color), or equivalent.

Compressor Oil Change

After the first six months of accumulated operation, or after 1,000 hours operation—whichever comes first—it is recommended to change the oil filter. It is recommended to subscribe to the Trane annual oil analysis program rather than automatically change the oil as part of scheduled maintenance. Change the oil only if indicated by the oil analysis. Use of an oil analysis program will reduce the chiller’s overall lifetime waste oil generation and minimize refrigerant emissions. The analysis determines system moisture content, acid level, and wear metal content; it can be used as a diagnostic tool. Due to the new refrigerant and oil combination, the oil analysis should be performed by the Trane Chemical Laboratory.

In conjunction with other diagnostics performed by a qualified service technician, oil analyses can provide valuable information on the performance of the chiller to help minimize operating and maintenance costs and maximize its operating life. An access valve is installed in the oil supply line, before the oil filter, for obtaining oil samples.

Notes:

- Use only Trane OIL00022. A full oil change is 79.5 L (21 gallons).

Leak Checking Based on Purge Pump Out Time

Figure 52 has been developed to aid in determining when to do a leak check of a chiller based on the purge pump out time and unit size. This figure depicts normal purge pump-out times, small leaks and large leaks based on the chiller tonnage.

If the purge pump-out time is in the small leak region, then a leak check should be performed and all leaks repaired at the earliest convenience. If the purge pump-out time is in the large leak region, a thorough leak check of the unit should be performed immediately to find and fix the leaks.

Recommended Maintenance

Figure 52. Purge operation under typical and leak conditions

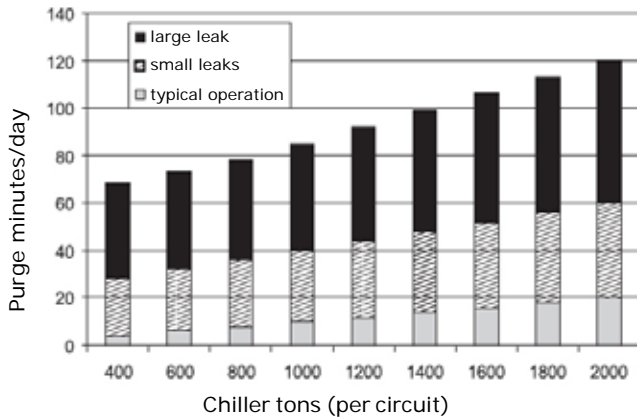

RuptureGuard Maintenance

It is recommended that the RuptureGuard be visually inspected and the relief valve pressure tested annually. The test can be performed with the valve in place and the refrigerant in the chiller.

The vent line drip leg must be periodically checked for accumulation of water or refrigerant. Drain any accumulation that may be present into an evacuated, properly labeled vessel and dispose of in accordance with local, state and federal codes.

EarthWise Purge Maintenance

Maintenance requirements for an EarthWise purge system with Tracer AdaptiView control are described in this section. To ensure efficient and reliable purge operation, perform all inspections and procedures at the prescribed intervals. Keep records of inspection results to establish proper service intervals. Document changes that occur in purge activity that could provide information about chiller performance.

⚠ WARNING

Contain Refrigerant!

Failure to follow proper procedures or the use of non-approved refrigerants, refrigerant substitutes, or refrigerant additives could result in death or serious injury or equipment damage. System contains oil and refrigerant under high pressure. Recover refrigerant to relieve pressure before opening the system. See unit nameplate for refrigerant type. Do not use non-approved refrigerants, refrigerant substitutes, or refrigerant additives.

⚠ WARNING

Hazardous Voltage!

Failure to disconnect power before servicing could result in death or serious injury. Disconnect all electric power, including remote disconnects before servicing. Follow proper lockout/ tagout procedures to ensure the power can not be inadvertently energized.



Note: Graphic labels (shown above) are used for CE application only.

Important:

- Before servicing, disconnect all power sources and allow at least 30 minutes for capacitors to discharge.
- All electrical enclosures—unit or remote—are IP2X.

⚠ CAUTION

Hot Surfaces!

Failure to follow instructions below could result in minor to severe burns. Surface temperatures may exceed 148.9°C (300°F) on condensing unit and carbon tank. Wear protective gear and allow surfaces to cool before servicing these parts or any part located in their vicinity.

Weekly Maintenance

Perform the following maintenance procedure on a weekly basis:

- With the purge unit operating, check the purge tank condensing activity by observing the liquid refrigerant flow in the moisture-indicating sight glass located in the liquid drain line immediately after the filter drier canister. A lack of visible refrigerant flow in the sight glass indicates one of the following:
 - A pump-out cycle is necessary
 - A problem exists with the purge heat transfer circuit (such as the condensing unit, expansion device, or purge evaporator coil)
 - A problem exists in the purge control subsystem
 - Refrigerant vapor from the chiller condenser is blocked or restricted
- Check the moisture-indicator sight glass. Replace the filter-drier core if moisture is indicated.

Note: The need for frequent changes of the filter drier could be an indication of significant chiller air or tube leaks.

Semi-Annual Maintenance

Perform the following maintenance procedure on a semi-annual basis:

- Inspect the air-cooled condenser coil and clean as needed. Clean the coil from the fan side using compressed air or coil cleaner. A dirty coil will reduce purge efficiency and capacity.
- Inspect the purge tank and carbon tank insulation for any damage or degradation. Make any needed repairs to the insulation.

Annual Maintenance

Perform the following maintenance procedure on an annual basis:

- Perform the semi-annual maintenance procedures.
- Open the purge control panel and check all internal components for such problems as corrosion, terminal tightness, or signs of overheating.
- Change the filter-drier assembly.

Inspecting the Moisture Indicator

Monitor the quality of the liquid refrigerant in the chiller by periodically inspecting the moisture indicator. The indicator will show “wet” whenever the chiller moisture exceeds the levels shown in [Table 22](#). Notice that the indicator becomes more sensitive as the temperature decreases. (The moisture indicator normally operates at equipment room ambient temperatures.)

A “wet” indication for more than 72 hours typically indicates that the filter-drier is saturated and should be replaced. In some cases in which a substantial amount of moisture has accumulated, such as when the chiller has been serviced, several filter-drier assembly changes may be required before a satisfactory moisture level is

achieved. A reoccurring or persistent “wet” indication is a sign of possible chiller air or water infiltration.

Inspect the moisture indicator only under the following conditions:

- The chiller is operating.
- The purge unit is operating and has been allowed sufficient time to properly remove system moisture (allow a minimum of 72 hours after replacing filter-drier).

Table 22. Refrigerant moisture content as determined by moisture indicator

Refrigerant moisture level	R-1233zd(E)		
	23.9°C (75°F)	37.8°C (100°F)	51.7°C (125°F)
Dry	Below 20	Below 30	Below 35
Caution	20–50	30–80	35–100
Wet	Above 50	Above 80	Above 100

Note: Refrigerant moisture content given in parts per million (ppm).

Maintaining the Moisture-Indicating Sight Glass

In normal operating conditions, the moisture-indicating sight glass should not require maintenance beyond keeping the sight glass clean. However, the sight glass should be replaced after any major repair to the unit has taken place, or if it is on a unit in which severe moisture contamination is known to have occurred.

Be aware that it is normal for the sight glass to indicate the presence of moisture for a period of least 72 hours after it is installed and after it has been exposed to atmosphere. Allow a minimum of 72 hours after sight glass installation or filter-drier service before using the sight glass to determine the system moisture content.

Removing Air After Servicing the Chiller

Air that leaks into a chiller during servicing needs to be removed so that the chiller can operate normally. The purge pump-out system, which performs this function, may operate for a long time to remove the air before cycling off for the first time. This is due to the large amount of non-condensables and the relatively small amount of refrigerant being drawn into the purge tank.

Important: Do not bypass or remove the pump-out restrictor of the EarthWise Purge system. Doing so could reduce the efficiency of the purge system. The purge system has a faster air exhaust rate than previous purge systems, which makes bypassing or removing the restrictor unnecessary.

The Daily Pumpout Limit determines how long the purge pump-out compressor can operate continuously without generating a Purge Daily Pumpout Exceeded diagnostic, which will shut off the purge system. You can disable the

Recommended Maintenance

Daily Pumpout Limit to allow the purge to pump out for an extended period of time.

Once the level of non-condensables present in the chiller falls to a point in which an increasing amount of refrigerant enters the purge tank, the pump-out compressor begins to cycle on and off. As the refrigerant in the system becomes less contaminated with non-condensables, purge pump-out is activated less frequently.

Note: If large amounts of non-condensables are present in the chiller, the air removal rate can be enhanced by operating the chiller at part-load conditions.

Leak Testing

⚠ WARNING

Hazard of Explosion!

Failure to follow recommended safe leak test procedures could result in death or serious injury or equipment or property-only-damage. Never use an open flame to detect gas leaks. Explosive conditions may occur. Use a leak test solution or other approved methods for leak testing.



Note: Graphic labels (shown above) are used for CE application only.

⚠ WARNING

Hazardous Pressures!

Failure to follow these safety precautions could result in a sudden rise of pressure possibly resulting in a violent explosion which could result in death or serious injury. If a heat source is required to raise the tank pressure during removal of refrigerant from cylinders, use only warm water or heat blankets to raise the tank temperature. Do not exceed a temperature of 150°F. Do not, under any circumstances apply direct flame to any portion of the cylinder.

Important: If leak testing is required, contact a Trane service agency.

Recommended System Maintenance

NOTICE:

Proper Water Treatment!

The use of untreated or improperly treated water in a CenTraVac could result in scaling, erosion, corrosion, algae or slime. It is recommended that the services of a qualified water treatment specialist be engaged to determine what water treatment, if any, is required. Trane assumes no responsibility for equipment failures which result from untreated or improperly treated water, or saline or brackish water.

Condenser

Condenser tube fouling is indicated when the approach temperature (the difference between the condensing refrigerant temperature and the leaving condenser water temperature) is higher than predicted.

If the annual condenser tube inspection indicates that the tubes are fouled, two cleaning methods, mechanical and chemical, can be used to rid the tubes of contaminants. Use the mechanical cleaning method to remove sludge and loose material from smooth-bore tubes.

To clean other types of tubes including internally-enhanced types, consult a qualified service organization for recommendations.

Figure 53. Typical chemical cleaning setup

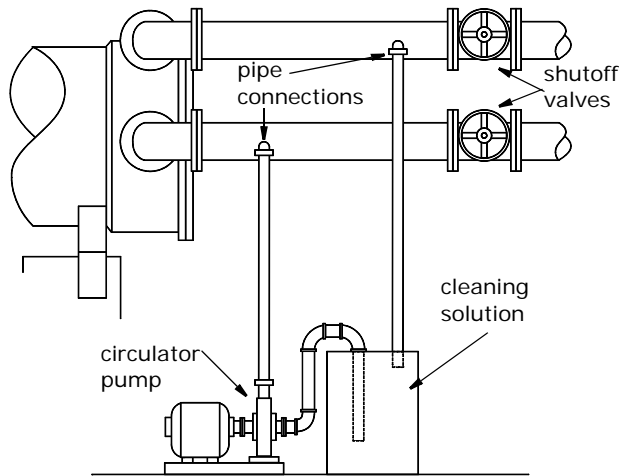

1. Follow all instructions in [“Waterbox Removal and Installation,”](#) p. 100 to remove waterbox covers.
2. Work a round nylon or brass bristled brush (attached to a rod) in and out of each of the condenser water tubes to loosen the sludge.
3. Thoroughly flush the condenser water tubes with clean water.

Scale deposits are best removed by chemical means. Be sure to consult any qualified chemical house in the area (one familiar with the local water supply's chemical mineral content) for a recommended cleaning solution suitable for the job.

Note: A standard condenser water circuit is composed solely of copper, cast iron, and steel.

NOTICE:

Unit Corrosion Damage!

Failure to follow proper procedures when using corrosive chemicals to clean water side of unit could result in corrosion damage to the unit and tubes. It is recommended that the services of a qualified chemical cleaning firm be used. Proper personal protective equipment as recommended by the chemical manufacturer should be used. Refer to the chemicals MSDS sheet for proper safety procedures.

Important: All of the materials used in the external circulation system, the quantity of the solution, the duration of the cleaning period, and any required safety precautions should be approved by the company furnishing the materials or performing the cleaning. Remember, however, that whenever the chemical tube cleaning method is used, it must be followed up with mechanical tube cleaning, flushing and inspection.

Evaporator

Since the evaporator is typically part of a closed circuit, it may not accumulate appreciable amounts of scale or sludge. Normally, cleaning every three years is sufficient. However, periodic inspection and cleaning is recommended on open evaporator systems, such as air washers.

Waterbox and Tubesheet Protective Coatings

Trane recommends that coated waterboxes/tubesheets—regardless of the type of protective coating included—be taken out of service within the first one to three months of operation for inspection. Any voids or defects identified upon inspection must be repaired. If the water quality is known to be highly supportive of corrosion (i.e., sea water, etc.), inspect the coating system at one month; if the water quality is known to be relatively benign (i.e., normal treated and clean condenser water), inspect the coating system within three months. Only when initial inspections show no problems are present should subsequent maintenance intervals be increased.

Sacrificial Anodes

The replacement schedule for the optional zinc or magnesium anodes can vary greatly with the aggressiveness of the water that is in the system. Some sites could require anode replacement every two to three months while other sites may require anode replacement every two to three years. Trane recommends that anode inspection for wear sometime within the first several months of the anodes being placed into service. If the observed loss of anode material is small, then the interval between subsequent inspections can be lengthened. Replace the anode and/or shorten the inspection interval if the anode has lost 50 percent or more of its original mass. If anode depletion occurs very quickly, consult a water treatment specialist to determine if the anode material selected is correct for the application.

NOTICE:

Equipment Damage!

Failure to follow instructions could result in equipment damage. Do NOT use Teflon-based tape or paste on anode; a small amount of liquid sealant (Loctite® 242 or equivalent) may be applied to prevent leakage when installing an anode, but do not apply so much sealant that it prevents the necessary electrical connection between the anode and the waterbox.

As needed after draining the waterbox, use a 63.5 mm (2-1/2 in.) wrench to remove/install Trane-supplied waterbox anodes.

Waterbox Removal and Installation

Important: Only qualified technicians should perform the installation and servicing of this equipment.

Discussion

This section will discuss recommended lifting. Proper lifting technique will vary based on mechanical room layout.

- It is the responsibility of the person(s) performing the work to be properly trained in the safe practice of rigging, lifting, securing, and fastening of the waterbox.
- It is the responsibility of the person(s) providing and using the rigging and lifting devices to inspect these devices to ensure they are free from defect and are rated to meet or exceed the published weight of the waterbox.
- Always use rigging and lifting devices in accordance with the applicable instructions for such device.

Procedure

⚠ WARNING

Heavy Objects!

Failure to properly lift waterbox could result in death or serious injury. Each of the individual cables (chains or slings) used to lift the waterbox must be capable of supporting the entire weight of the waterbox. The cables (chains or slings) must be rated for overhead lifting applications with an acceptable working load limit. Refer to [Table 24, p. 101](#) for waterbox weights.

Review mechanical room limitations and determine the safest method or methods of rigging and lifting the waterboxes.

1. Determine the type and size of chiller being serviced. Refer to Trane nameplate located on chiller control panel.

Important: This literature contains rigging and lifting information only for Trane CTV chillers built in La Crosse. For Trane CTV chillers built outside the United States, refer to literature provided by the applicable manufacturing location.

2. The rated lifting capacity of the lifting shackle must meet or exceed the published weight of the waterbox. Verify the waterbox weight from the latest published literature.
3. Ensure that the lift connection device has the correct size for the waterbox lifting hole.
4. Properly connect the shackle to the waterbox. [Figure 54, p. 100](#)

5. Disconnect water pipes, if connected.
6. Remove waterbox bolts.
7. Lift the waterbox away from the shell.

Figure 54. Waterbox lifting—condenser and evaporator lifting points

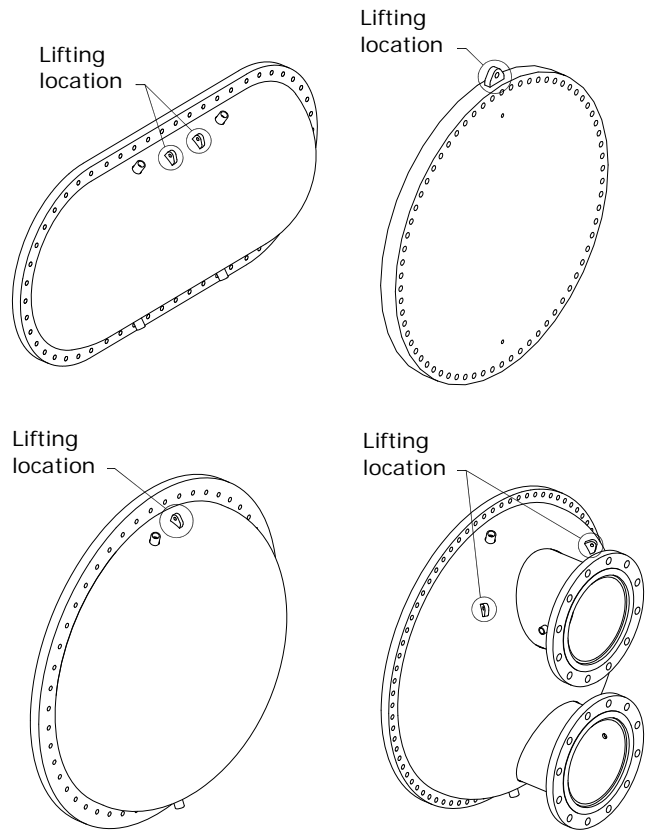

⚠ WARNING

Overhead Hazard!

Failure to follow instructions could result in death or serious injuries. Never stand below or in close proximity to heavy objects while they are suspended from, or being lifted by, a lifting device in case the object drops.

8. Store waterbox in a safe and secure location and position.

Note: Do not leave waterbox suspended from lifting device.

Reassembly

Once service is complete, the waterbox should be reinstalled on the shell following all previous procedures in reverse. Use new O-rings or gaskets on all joints after thoroughly cleaning each joint.

- Torque waterbox bolts (see [Table 23](#)).

Torque Requirements

Table 23. CenTraVac torque

Bolt Size in. (mm)	Gasket type O-ring N·m (ft·lb)	Flat N·m (ft·lb)
3/8	33.9 (25)	16.3–24.4 (12–18)
1/2	94.9 (70)	44.7–67.8 (33–50)
5/8	203.4 (150)	94.9–122.0 (70–90)
3/4	339.0 (250)	142.4–210.2 (105–155)

Table 24. CVHH waterbox weights

Shell Size	Description	Non-Marine Plate		Non-Marine Dome		Marine Plate Cover		Marine Dome Cover		Marine Waterbox	
		Weight kg (lb)	Lifting Hole mm (in.)	Weight kg (lb)	Lifting Hole mm (in.)	Weight kg (lb)	Lifting Hole mm (in.)	Weight kg (lb)	Lifting Hole mm (in.)	Weight kg (lb)	Lifting Hole mm (in.)
100	Evaporator, 1034.2 kPaG (150 psig)	NA	NA	314 (693)	11.9 (0.469)	NA	NA	258 (569)	11.9 (0.469)	586 (1292)	21.8 (0.858)
	Evaporator, 2068.4 kPaG (300 psig)	369 (814)	11.9 (0.469)	NA	NA	369 (814)	11.9 (0.469)	NA	NA	619 (1365)	35.1 (1.38)
	Condenser, 1034.2 kPaG (150 psig)	NA	NA	203 (448)	11.9 (0.469)	NA	NA	147 (324)	11.9 (0.469)	432 (953)	21.8 (0.858)
	Condenser, 2068.4 kPaG (300 psig)	NA	NA	291 (642)	11.9 (0.469)	NA	NA	198 (436)	11.9 (0.469)	542 (1195)	21.8 (0.858)
130	Evaporator, 1034.2 kPaG (150 psig)	NA	NA	347 (766)	11.9 (0.469)	NA	NA	292 (645)	11.9 (0.469)	645 (1423)	21.8 (0.858)
	Evaporator, 2068.4 kPaG (300 psig)	431 (950)	11.9 (0.469)	NA	NA	320 (705)	11.9 (0.469)	NA	NA	693 (1527)	35.1 (1.38)
	Condenser, 1034.2 kPaG (150 psig)	NA	NA	267 (589)	11.9 (0.469)	NA	NA	185 (409)	11.9 (0.469)	529 (1166)	21.8 (0.858)
	Condenser, 2068.4 kPaG (300 psig)	NA	NA	386 (851)	11.9 (0.469)	NA	NA	255 (562)	11.9 (0.469)	686 (1513)	21.8 (0.858)
160	Evaporator, 1034.2 kPaG (150 psig)	NA	NA	391 (863)	11.9 (0.469)	NA	NA	310 (683)	11.9 (0.469)	822 (1813)	21.8 (0.858)
	Evaporator, 2068.4 kPaG (300 psig)	544 (1200)	11.9 (0.469)	NA	NA	411 (906)	11.9 (0.469)	NA	NA	878 (1937)	35.1 (1.38)
200	Evaporator, 1034.2 kPaG (150 psig)	NA	NA	295 (652)	11.9 (0.469)	581 (1282)	11.9 (0.469)	NA	NA	870 (1918)	35.1 (1.38)
	Evaporator, 2068.4 kPaG (300 psig)	1003 (2211)	11.9 (0.469)	NA	NA	799 (1763)	11.9 (0.469)	NA	NA	1292 (2849)	35.1 (1.38)
	Condenser, 1034.2 kPaG (150 psig)	NA	NA	317 (700)	11.9 (0.469)	NA	11.9 (0.469)	NA	NA	700 (1544)	21.8 (0.858)
	Condenser, 2068.4 kPaG (300 psig)	NA	NA	NA	11.9 (0.469)	782 (1724)	11.9 (0.469)	NA	NA	970 (2138)	21.8 (0.858)
220	Evaporator, 1034.2 kPaG (150 psig)	NA	NA	364 (802)	11.9 (0.469)	772 (1702)	11.9 (0.469)	NA	NA	1214 (2677)	35.1 (1.38)
	Evaporator, 2068.4 kPaG (300 psig)	1459 (3218)	11.9 (0.469)	NA	NA	1123 (2476)	11.9 (0.469)	NA	NA	1876 (4137)	35.1 (1.38)
	Condenser, 1034.2 kPaG (150 psig)	NA	NA	346 (763)	11.9 (0.469)	NA	NA	246 (543)	11.9 (0.469)	724 (1598)	21.8 (0.858)
	Condenser, 2068.4 kPaG (300 psig)	NA	NA	513 (1132)	11.9 (0.469)	NA	NA	321 (708)	11.9 (0.469)	862 (1901)	21.8 (0.858)

Waterbox Removal and Installation

Table 24. CVHH waterbox weights (continued)

Shell Size	Description	Non-Marine Plate		Non-Marine Dome		Marine Plate Cover		Marine Dome Cover		Marine Waterbox	
		Weight kg (lb)	Lifting Hole mm (in.)	Weight kg (lb)	Lifting Hole mm (in.)	Weight kg (lb)	Lifting Hole mm (in.)	Weight kg (lb)	Lifting Hole mm (in.)	Weight kg (lb)	Lifting Hole mm (in.)
10H	Heat Recovery Condenser, 1034.2 kPaG (150 psig)	917 (2022)	21.8 (0.858)	NA	NA	NA	NA	NA	NA	NA	NA
13H	Heat Recovery Condenser, 1034.2 kPaG (150 psig)	1106 (2439)	21.8 (0.858)	NA	NA	NA	NA	NA	NA	NA	NA
20H	Heat Recovery Condenser, 1034.2 kPaG (150 psig)	1247 (2750)	21.8 (0.858)	NA	NA	NA	NA	NA	NA	NA	NA
22H	Heat Recovery Condenser, 1034.2 kPaG (150 psig)	1747 (3853)	21.8 (0.858)	NA	NA	NA	NA	NA	NA	NA	NA

Bolt-Tightening Sequence for Waterboxes

Evaporator Waterbox Covers

Ensure that the waterbox head rests tightly against the tube sheet, and then snugly tighten the bolts in sequential order as shown in the figure below. If excessive tube sheet crown prevents the head from contacting the tube sheet, tighten the bolts located where the greatest gaps occur. Be sure to use an equal number of bolt turns from side to side. Then, apply final torque to each bolt in sequential order.

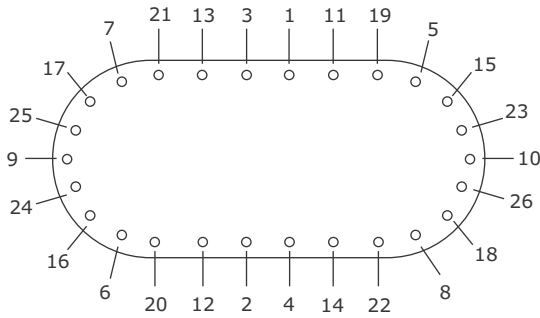

Condenser Waterbox Covers

Condenser waterbox covers use a similar procedure to that which is used for the evaporator waterbox covers. Use a crossing pattern as shown in the following figure.

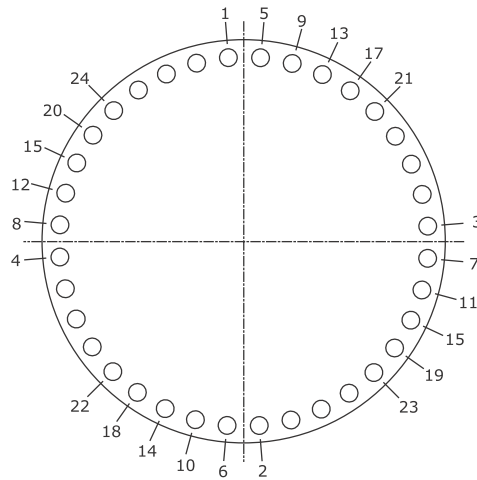

Heat Recovery Condenser Waterbox Covers

For heat recovery condenser waterbox covers, torque the bolts along the center divider of the waterbox first (1A, 2A, 3A, etc), and then torque the bolts around the outside of the waterbox (1B, 2B, 3B, etc).

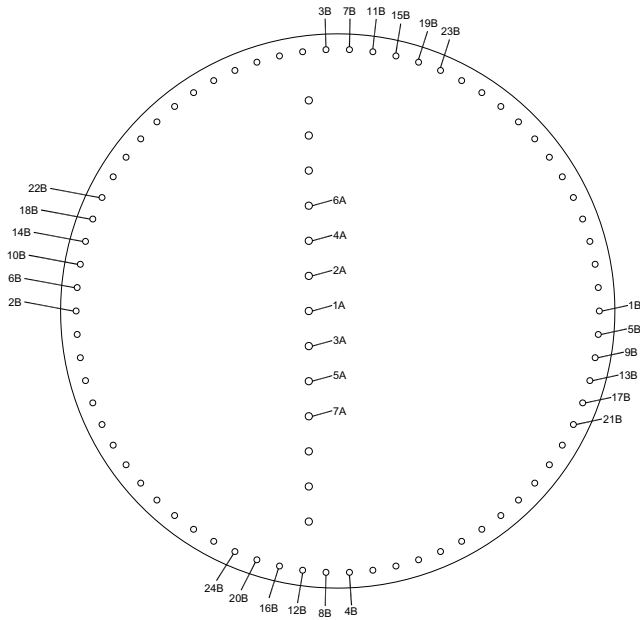



Forms and Check Sheets

The following forms and check sheets are included for use with Trane start-up of CVHH CenTraVac chillers. Forms and check sheets are used, as appropriate, for installation completion verification before Trane start-up is scheduled, and for reference during the Trane start-up.

Where the form or check sheet also exists outside of this publication as standalone literature, the literature order number is also listed.

- [“CenTraVac™ Installation Completion Check Sheet and Request for Trane Service” \(CTV-ADF001*-EN\)](#)
- [“CVHH Start-up Task List”](#)
- [“CVHH Annual Inspection List”](#)
- [“Operator Log”](#)



CenTraVac™ Installation Completion Check Sheet and Request for Trane Service

Important: A copy of this completed form must be submitted to the Trane service office that will be responsible for the start-up of the chiller. Start-up will NOT proceed unless applicable items listed in this form have been satisfactorily completed.

To: _____ Trane Service Office: _____

S.O. Number: _____ Serial Numbers: _____

Job/Project Name: _____

Address: _____

The following items are being installed and will be completed by: _____

Important: Start-up must be performed by Trane or an agent of Trane specifically authorized to perform start-up and warranty of Trane® products. Contractor shall provide Trane (or an agent of Trane specifically authorized to perform start-up) with notice of the scheduled start-up at least two weeks prior to the scheduled start-up. Equipment not started by Trane is not warranted by Trane.

Check box if the task is complete or if the answer is "yes."

1. CenTraVac

In place and piped.

Note: Do not insulate the CenTraVac chiller or adjacent piping prior to the chiller commissioning by Trane service personnel. The contractor is responsible for any foreign material left in the unit.

2. Piping

Chilled water piping connected to:

- CenTraVac
- Air handling units
- Pumps

Condenser and heat recovery condenser (as applicable) piping connected to:

- CenTraVac
- Pumps
- Cooling tower
- Heating loop (as applicable)

- Make-up water connected to cooling tower
- Water supply connected to filling system
- Systems filled

- Pumps run, air bled from system
- Strainers cleaned
- Rupture disk or RuptureGuard™ ventilation piping installed

3. Flow balancing valves installed

Leaving chilled water

Leaving condenser water

Optional heat recovery or auxiliary condenser water

4. Gauges, thermometers, and air vents

Installed on both sides of evaporator

Installed on both sides of condenser and heat recovery condenser (as applicable)

5. Wiring

Compressor motor starter has been furnished by Trane, or has been configured and installed in compliance with the appropriate Trane Starter by Others specification (available from your local Trane Sales Office)

- Full power available
- Interconnecting wiring, starter to panel (as required)
- External interlocks (flow switch, pumps auxiliary, etc.)
- Chiller motor connection (remote starters)

- Chilled water pump (connected and tested)
- Condenser water pump (connected and tested)
- Cooling tower fan rotation checked
- Heat recovery condenser water pump (as applicable)
- 115 Vac power available for service tools
- All controls installed and connected
- All magnetic starters installed and connected

Note: Do not make final remote starter-to-compressor motor connections until requested to do so by the Trane service representative!

6. Testing

Dry nitrogen available for pressure testing (for disassembled units)

Material and equipment available for leak testing, if necessary

7. Refrigerant on job site and in close proximity to chiller

Total amount in cylinders/drums: _____ (specify lb or kg) and fill in specifics below:

Number of cylinders/drums ____ of size _____ (specify lb or kg)

Number of cylinders/drums ____ of size _____ (specify lb or kg)

Note: After commissioning is complete, it is the installer's responsibility to transport empty refrigerant containers to an easily accessible point of loading to facilitate container return or recycling.

8. Systems can be operated under load conditions

9. Electrical, control man, and contractor's representative are available to evacuate, charge, and test the CenTraVac under serviceman's supervision

10. Equipment room

Does the equipment room have a refrigerant monitor/sensor capable of monitoring and alarming within the allowable exposure level of the refrigerant?

Does the equipment room have proper mechanical ventilation?

Does the installation have properly placed and operating audible and visual refrigerant alarms?

If it is required by local code, is a self-contained breathing apparatus available?

11. Owner awareness

Has the owner been fully instructed on the proper use and handling of refrigerant?

Does the owner have a copy of the MSDS for refrigerant?

Note: Additional time required to properly complete the start-up and commissioning, due to any incompleteness of the installation, will be invoiced at prevailing rates.

This is to certify that the Trane® equipment has been properly and completely installed, and that the applicable items listed above have been satisfactorily completed.

Checklist completed by (print name): _____

Signature: _____ Date: _____

In accordance with your quotation and our purchase order number _____, we will therefore require the presence of Trane service on this site, for the purpose of start-up and commissioning, by _____ (date).

Note: Minimum two-week advance notification is required to allow scheduling of the chiller start-up.

Additional comments/instructions:

This document and the information in it are the property of Trane, and may not be used or reproduced in whole or in part without written permission. Trane reserves the right to revise this publication at any time, and to make changes to its content without obligation to notify any person of such revision or change. All trademarks referenced in this document are the trademarks of their respective owners.



Trane optimizes the performance of homes and buildings around the world. A business of Ingersoll Rand, the leader in creating and sustaining safe, comfortable and energy efficient environments, Trane offers a broad portfolio of advanced controls and HVAC systems, comprehensive building services, and parts. For more information, visit www.Trane.com.

Trane has a policy of continuous product and product data improvement and reserves the right to change design and specifications without notice.





CVHH Start-up Task List

Start-up Tasks to be Performed By Trane

⚠ WARNING

Safety Alert!

In addition to the following tasks, you **MUST**:

- Follow all instructions in the chiller's *Installation, Operation, and Maintenance* manual, including warnings, cautions, and notices.
- Perform all required tasks in any applicable Service Alerts and Service Bulletins.
- Review and understand all information provided in Submittals and Design Specifications.

Failure to do so could result in death or serious injury.

General

- Inspect chiller for damage (shipping or rigging).
- Verify and record unit nitrogen holding charge pressure.
- Inspect water piping for proper installation.
 - Inspect strainers, flow sensing devices, isolation valves, pressure gauges, thermometer wells, flow balancing valves, vent cocks, and drains.
 - Inspect cooling tower piping.
- Verify proper clearances.
- Power wiring meets size requirement.
 - Verify proper voltage and amperage rating.
- Verify proper foundation installation.
- Verify unit isolator pads/springs have been installed.
- Verify low voltage circuits are isolated from high voltage circuits.
- Check equipment room for ventilation, refrigerant monitor, rupture disk piping, and PPE.

Note: All conditions which do not conform to the established requirements for unit installation must be corrected prior to start-up. Any non-conforming condition which is not corrected prior to start-up must be noted in the Non-Compliance Form (PROD-ADF001-EN) by the start-up technician; this information must also be signed by responsible site personnel before start-up and the completed Non-Compliance Form will become part of the start-up record, submitted with a Start-up Check Sheet and a Chiller Service Report.*

Pre-Start Operations

- Verify nitrogen holding charge.
- Calibrate the high pressure cutout control (HPC).
- Meg compressor motor.
- Check condenser installation.
- Check evaporator installation.

NOTICE:

Do Not Apply Electrical Power to a Unit in a Vacuum!

Failure to disconnect power to units with inside-the-delta solid state starters during evacuation or when the unit is in a deep vacuum could cause compressor motor damage. Applying electrical power to a motor in a vacuum could cause damage to the motor. In addition, on units with inside-the-delta solid state starters, all power to the unit must be disconnected prior to evacuating the unit as line power is directly applied to the motor terminals 4, 5, and 6.

- Check electrical and controls.
 - Inspect motor starter and control panel.
 - Confirm all wiring connections are tight, free of abrasion and have no sharp bends in panel and on compressors.
 - Inspect contactors and relays.
 - Verify unit wiring (low and high voltage) is correctly isolated, phased, and properly grounded.
 - Connect external 120 Vac power to power up the control panel.

- Run the oil pump to verify pump can provide 137.9 to 165.5 kPaD (20 to 24 psid) net pressure.
- Verify and record control parameters.
- Verify all control interlocks are installed and properly functioning.
- Dry run starter (non-AFD).
- Measure condenser pressures and flow.
- Adjust condenser flow sensing device.
- Measure evaporator pressures and flow.
- Adjust evaporator flow sensing device.
- Inspect motor starter panel and perform starter panel checkout procedures.
- Confirm proper phase check incoming power.
- Inspect control panel.
- Apply separate source 120 Vac power to control to perform control panel checkout procedure.
- Review and record unit configuration parameters.
- Verify the operation of the oil tank vent valve.
- Verify that the oil cooling line valve actuates.
- Verify vane operator is working properly and moves without binding.
- Dry run test starter (non-AFD).
- Remove separate source power and reconnect wiring.

Preparation for Start-up

- Relieve nitrogen holding charge.
- Confirm proper oil pump operation.
- Confirm oil pump pressure—regulating valve setting.
- Evacuate and charge the system.
- Apply power to the starter panel.
- Verify current to the oil sump heater.

Chiller Start-up

- Set Purge mode to “On.”
- Bump-start the compressor and verify compressor motor rotation.
- Start chiller.
- Verify no unusual noises or vibrations and observe operating conditions.
- If necessary, adjust oil pressure regulator between 137.9 to 165.5 kPaD (20 to 24 psid) net.
- Measure and verify refrigerant pump pressure.
- When chiller is stable, take system log three times at 15-minute intervals.
- Set Purge mode to “Adaptive.”
- Reset the “Starter Energy Consumption” resettable.
- Record a Chiller Service Report.
- Review “AdaptiView Display Customer Training Checklist.”
 - Equipment Description
 - Stopping/Starting Chiller Operation
 - Alarms
 - Reports
 - Data Graphs
 - Equipment Settings
 - Display Settings
 - Security Settings
 - Basic Troubleshooting



CVHH Annual Inspection List

Follow the annual maintenance instructions provided in the text of this manual, including but not limited to:

Compressor Motor

- Motor continuity.
- Motor meg test.
- Check motor terminals.
- Inspect motor terminal board.

Starter or AFD

- Inspect starter contacts.
- Check all connections per manufacturer specifications.
- Follow all manufacturer recommendations for starter or AFD maintenance.
- Inspect/clean/service the AFD cooling system (water- or air-cooled AFD).
- Record all applicable starter or starter component settings.

Oil System

- Annual oil analysis (follow recommendations).
- Clean and lubricate oil system as required.
- Electrical inspection.
- Pump motor continuity check.
- Run oil pump and check differential oil pressure.

Condenser

- Inspect for fouling and scaling in tubes.
- Check operation of condenser water flow sensing device.
- Factory recommendation to eddy current test tubes every three years.

Evaporator

- Inspect for fouling and scaling in tubes.
- Check operation of evaporator water flow sensing device.
- Factory recommendation to eddy current test tubes every three years.

Control Circuits

- Verify control parameters.
- Test appropriate sensors for accuracy.
- Ensure sensors are properly seated in wells with thermopaste installed.
- Check evaporator leaving water temperature low temperature cutout setpoint.
- Condenser high pressure switch check-out.
- Check adjustment and operation of the inlet guide vane actuator.

Leak Test Chiller

- Check purge times and unit performance logs. If warranted, pressure leak test.
- Review oil analysis. If required, submit refrigerant sample for analysis.
- Inspect unit for any signs of refrigerant or oil leakage.
- Check unit for any loose bolts on flange, volutes, or casing.

Purge Unit

- Review this manual and follow maintenance and/or inspection items identified.
- Review purge pump out data.
- Review overall operation of purge and service as necessary.

Exterior

- Inlet guide vane linkage.
- Clean and touch-up painted surfaces as needed.
- Repair deteriorated, torn, or missing insulation.



Optional Accessories

- If applicable, lubricate factory-installed gantries.
- After the first month of operation, inspect Heresite® or Belzona® coated waterboxes after first month; thereafter, inspect as needed.
- Inspect anodes.
- Inspect and lubricate hinged waterboxes.
- With water flow sensing option, bleed tubing from waterboxes to transformers.



Operator Log

Water-Cooled CVHH CenTraVac Chiller with UC800 Controller

Tracer AdaptiView Reports—Log Sheet	Log 1	Log 2	Log 3
Evaporator			
Entering			
Leaving			
Saturated			
Refrig. Press			
Approach			
Flow Sw Status			
Condenser			
Entering			
Leaving			
Saturated			
Refrig. Press			
Approach			
Flow Sw Status			
Compressor			
Starts			
Running Time			
Oil Tank Press			
Oil Discharge Press			
Oil Diff Press			
Oil Tank Temp			
IGV Position %			
Outboard Bearing Pad Temperature #1			
Outboard Bearing Pad Temperature #2			
Outboard Bearing Pad Temperature #3			
Motor			
% RLA L1, L2, L3			
Amps L1, L2, L3			
Volts AB, BC, CA			
Power KW			
Load PF			
Winding #1 Temp			
Winding #2 Temp			
Winding #3 Temp			
with AFD only			
AFD Freq			
AFD Speed			
AFD Transistor Temp			
Purge			
Time Until Next Purge Run			
Daily Pumpout—24 hrs			
Avg. Daily Pumpout—7 days			
Daily Pumpout Limit/Alarm			
Chiller On—7 days			
Pumpout Chiller On—7 days			
Pumpout Chiller Off—7 days			
Pumpout—Life			
Purge Rfgr Cprsr Suction Temp.			
Purge Liquid Temp.			
Carbon Tank Temp.			

Date:

Technician:

Owner:



Trane optimizes the performance of homes and buildings around the world. A business of Ingersoll Rand, the leader in creating and sustaining safe, comfortable and energy efficient environments, Trane offers a broad portfolio of advanced controls and HVAC systems, comprehensive building services, and parts. For more information, visit www.Trane.com.

Trane has a policy of continuous product and product data improvement and reserves the right to change design and specifications without notice.